

Ersatzteilliste

(1.280-107.0) KM 100/100 R Lpg

Inhaltsverzeichnis

KM 100/100 R Lpg (1.280-107.0)	4
ETL KM 100/100 P (5.963-737.0)	5
10 Rahmen	6
11 Rahmen	7
12 Einzelteile	10
20 Seitenbesen	12
30 Lenkung	14
40 Sitz	16
50 Verkleidung	18
60 Filterkasten	21
70 Pedal	23
80 Kehrwalzenkasten	25
81 Kehrbehälter	26
82 Kehrwalze	28
90 Antrieb Motor Benzin GX270UT2	30
91 Motor	31
2 Auspuff (4.462-140.0)	34
92 Fahrtrieb	35
93 Gebläse	37
100 UBS Keilriemen KM100/100 (2.850-925.0)	40
94 Antrieb	41
95 Einzelteile Motor Honda GX270UT2	44
100 Antrieb Motor Benzin GX270	46
400 Auspuff (4.462-140.0)	51
540 Gebläse Benzin T3	52
640 Steuerblock Antrieb KM 100/100 (4.040-328.0)	55
650 Antrieb Achse T3 KM100/100 (4.040-197.0)	57
110 Steuerung Pedal Verbrenner	61
120 Anbauteile Achse	63
130 Konsole	66
140 Hydraulik	68
150 Hydraulik	70
160 Pneumatik	72
12 UBS Anhebung Seitenbesen B/D/LPG (2.641-693.0)	75
60 Staubschutz Unterdruckdose oval (4.040-815.0)	77
15 Staubschutz Unterdruckdose oval (4.040-815.0)	78
38 UBS Unterdruckdose Antrieb KM 100/100 B/ (2.641-699.0)	79
170 E-Ausrüstung	81

Inhaltsverzeichnis

180 Gas	83
22 Deckel Set Lpg (4.040-023.0)	86
29 Magnetventil LPG Absperrventil (6.686-116.0)	87
190 UBS KM 100/100 R LPG	88
2 Gas Set KM	92
16 Magnetventil LPG Absperrventil (6.686-116.0)	94
200 ABS Besen Steuerung	95
210 ABS Rundumkennleuchte LED KM 90/60 (2.643-887.0)	97
60 Rundumkennleuchte LED kpl.	100

KM 100/100 R Lpg (1.280-107.0)

POS	Artikelnr.	Beschreibung	Anzahl	Einheit
0	5.963-737.0	ETL KM 100/100 P	1.000	ST
Positionstext2: 3D6E371D00C0647CE1000000C34F56CF12801060				

ETL KM 100/100 P (5.963-737.0)

POS	Artikelnr.	Beschreibung	Anzahl	Einheit	Bemerkung
10		Rahmen	1.000	ST	
20		Seitenbesen	1.000	ST	
30		Lenkung	1.000	ST	
40		Sitz	1.000	ST	
50		Verkleidung	1.000	ST	
60		Filterkasten	1.000	ST	
70		Pedal	1.000	ST	
80		Kehrwalzenkasten	1.000	ST	
90		Antrieb Motor Benzin GX270UT2	1.000	ST	
100		Antrieb Motor Benzin GX270	1.000	ST	Version 2
110		Steuerung Pedal Verbrenner	1.000	ST	Version 2
120		Anbauteile Achse	1.000	ST	
130		Konsole	1.000	ST	
140		Hydraulik	1.000	ST	1.280-105.0
150		Hydraulik	1.000	ST	1.280-107.0
160		Pneumatik	1.000	ST	
170		E-Ausruestung	1.000	ST	
180		Gas	1.000	ST	
190		UBS KM 100/100 R LPG	1.000	ST	
200		ABS Besen Steuerung	1.000	ST	
210	2.643-887.0	ABS Rundumkennleuchte LED KM 90/60	1.000	ST	

10 Rahmen

POS	Beschreibung	Anzahl	Einheit
11	Rahmen	1.000	ST
12	Einzelteile	1.000	ST

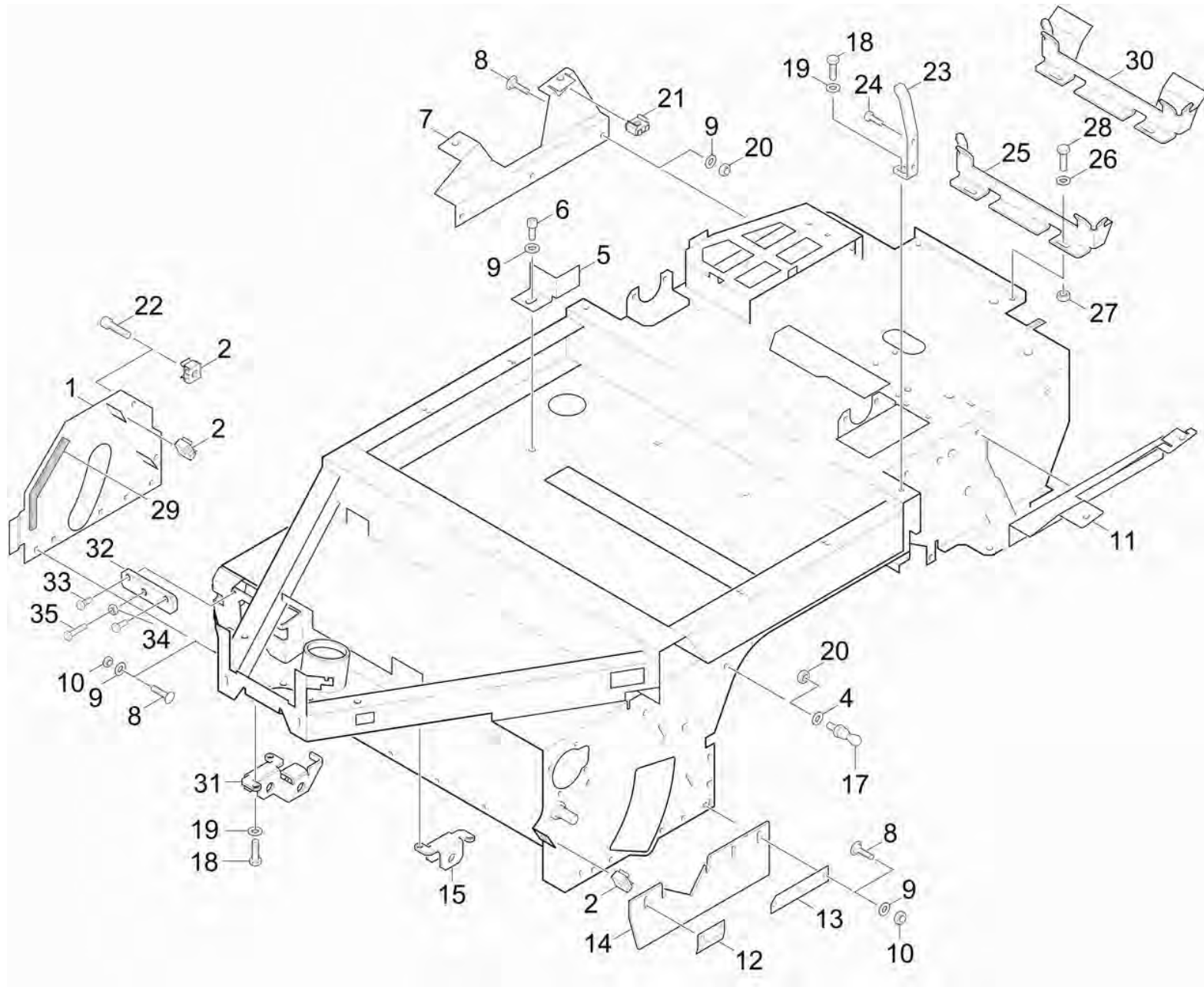

11 Rahmen

POS	Artikelnr.	Beschreibung	Anzahl	Einheit	Fußnotentext
1	4.040-091.0	Blechteil kpl.	1.000	ST	
2	6.310-020.0	Kaefigmutter M 6	8.000	ST	
4	7.312-002.0	Scheibe 5-200HV-A3E ISO 7090	4.000	ST	
5	5.059-781.0	Blechteil Rahmen	1.000	ST	
6	6.303-031.0	Schraube M8x16-ST-R2R DIN 7500-1	1.000	ST	
7	5.059-898.0	Blechteil rechts (SP)	1.000	ST	
8	7.303-139.0	Fl.Rd.Schr. M6x20 -A2 DIN 603	22.000	ST	
9	7.312-003.0	Scheibe 6 -200HV-A3E ISO 7090	22.000	ST	
10	7.311-512.0	6kt-Mutter M 6-8-A2E ISO 7040	16.000	ST	
11	5.059-902.0	Blechteil links (SP)	1.000	ST	
12	5.190-216.0	Leiste Seite	2.000	ST	
13	5.190-215.0	Leiste Seite hinten	2.000	ST	
14	5.365-250.0	Gummilippe Seite	2.000	ST	
15	5.059-731.0	Blechteil links (SP)	1.000	ST	
17	5.108-198.0	Verschlusszapfen kurz	4.000	ST	
18	7.304-397.0	6kt-Schraube M8x20-8.8-A2E ISO 4017	6.000	ST	
19	7.312-004.0	Scheibe 8 -200HV-A3E ISO 7090	6.000	ST	
20	7.311-425.0	6kt-Mutter M6 -04-A2E ISO 10511	4.000	ST	
21	6.310-135.0	Kaefigmutter M8 3,3/4,7MM	4.000	ST	
22	7.306-192.0	Schraube M 6x 12-A2-70 (In6Rd)	2.000	ST	
23	5.058-520.0	Blechteil	2.000	ST	
24	6.303-125.0	Schraube 5x20-Sonder In6Rd+Spitze	4.000	ST	
25	5.058-521.0	Blechteil hinten	1.000	ST	
26	7.312-260.0	Scheibe 6 -100HV-A3E ISO 7094	2.000	ST	
27	7.311-033.0	6kt-Mutter A G 1"-1.4571 DIN 431	6.000	ST	
28	7.306-092.0	Schraube M6x20-ST- 8.8-R3R (IN6RD)	2.000	ST	
29	2.273-000.0	Dichtband Zellgummi 9x4, 20m	1.000	ST	
29	6.273-043.0	Dichtband Zellgummi 9x4	1.000	M	
30	5.061-293.0	Blechteil hinten Zentrierhilfe	1.000	ST	NUR FUER UMBAU
31	5.061-890.0	Blechteil Halter rechts	1.000	ST	
32	5.094-400.0	Blechteil Verstellung	1.000	ST	
33	7.306-094.0	Schraube M6x25 -8.8-R3R (In6Rd)	2.000	ST	
34	7.311-224.0	6kt-Mutter M 8-04-A2E ISO 4035	1.000	ST	

11 Rahmen

POS	Artikelnr.	Beschreibung	Anzahl	Einheit	Fußnotentext
35	7.304-407.0	6kt-Schraube M 8x45-8.8-A2E ISO 4017	1.000	ST	

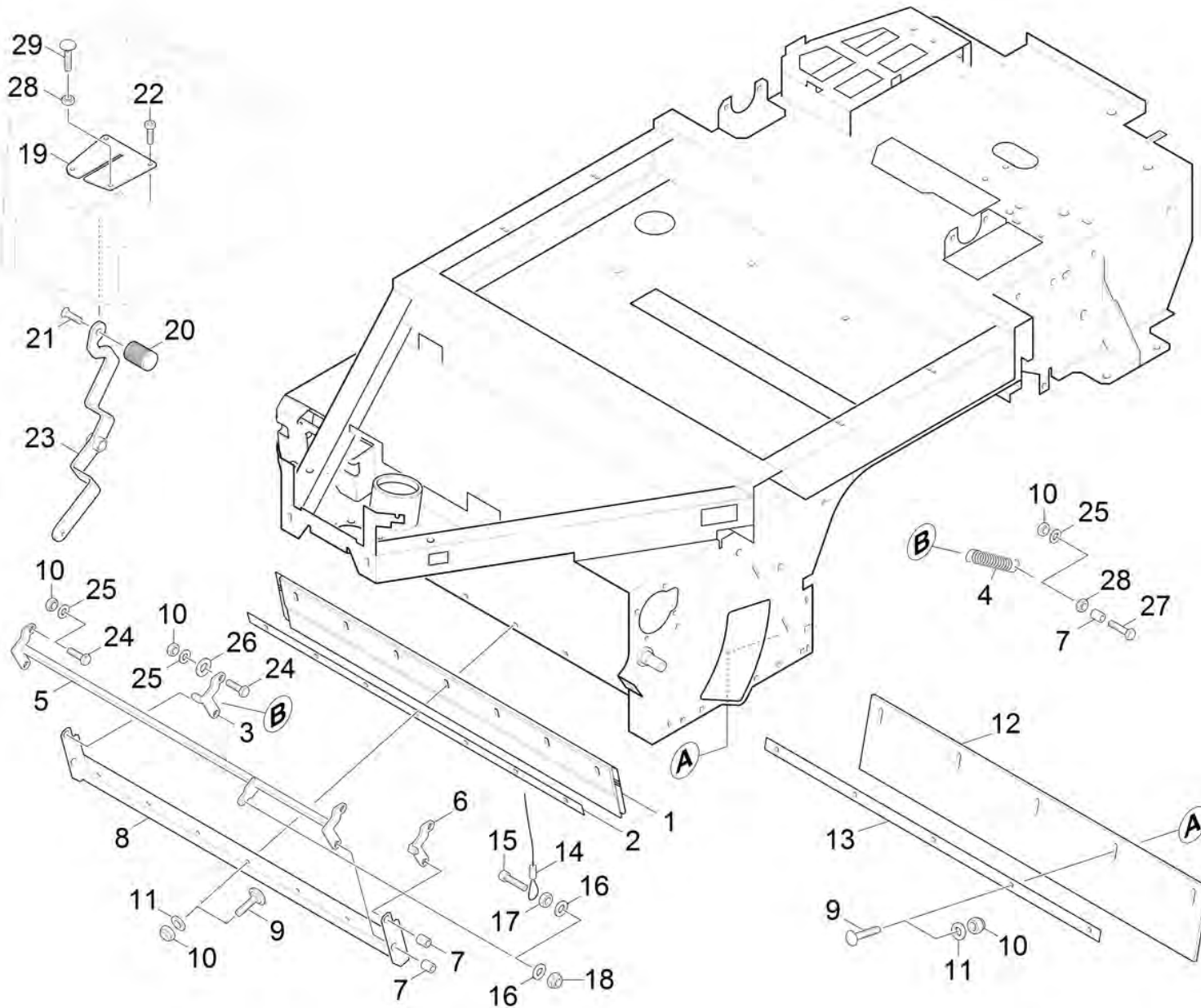

12 Einzelteile

POS	Artikelnr.	Beschreibung	Anzahl	Einheit
1	5.394-648.0	Schuerze GSK	1.000	ST
2	5.007-562.0	Blech Leiste GSK	1.000	ST
3	5.059-973.0	Blechteil rechts GSK	1.000	ST
4	6.330-421.0	Zugfeder	2.000	ST
5	4.040-070.0	Blechteil kpl.	1.000	ST
6	5.059-974.0	Blechteil links GSK	1.000	ST
7	5.112-676.0	Buchse GSK	8.000	ST
8	5.059-797.0	Blechteil GSK	1.000	ST
9	7.303-139.0	Fl.Rd.Schr. M6x20 -A2 DIN 603	22.000	ST
10	7.311-425.0	6kt-Mutter M6 -04-A2E ISO 10511	36.000	ST
11	7.312-003.0	Scheibe 6 -200HV-A3E ISO 7090	12.000	ST
12	5.365-249.0	Gummilippe hinten	1.000	ST
13	5.190-055.0	Leiste	1.000	ST
14	6.437-518.0	Seil	1.000	ST
15	7.306-158.0	Zyl.Schr. M 5x20-A4-70 ISO 4762	1.000	ST
16	7.312-052.0	Scheibe 5 -A2 ISO 7089	2.000	ST
17	7.311-203.0	6kt-Mutter M5 -A4-035 ISO 4035	1.000	ST
18	7.311-029.0	6kt-Mutter M 5-A4-70 ISO 7042	1.000	ST
19	7.777-999.0	Bevorratung eingestellt	1.000	ST
20	5.321-701.0	Griff	1.000	ST
21	7.306-063.0	Zyl.Schr. M10x30-8.8-A3E ISO4762	1.000	ST
22	7.306-089.0	Schraube M6x12 -8.8-R2R (In6Rd)	3.000	ST
23	4.040-835.0	Blechteil kpl. Grobschmutzklappe	1.000	ST
24	7.304-509.0	6kt-Schraube M 6x25-A4-70 ISO 4017	6.000	ST
25	7.312-292.0	Scheibe 6 -A2 ISO 7093-1	17.000	ST
26	7.312-005.0	Scheibe 10-200HV-A3E ISO 7090	8.000	ST
27	7.304-549.0	6kt-Schraube M 6x30-A4-70 ISO 4017	2.000	ST
28	7.311-003.0	6kt-Mutter M6 -8-A2E ISO 4032	2.000	ST
29	7.303-190.0	Fl.Rd.Schr. M6x35-ST-A0P DIN 603	1.000	ST

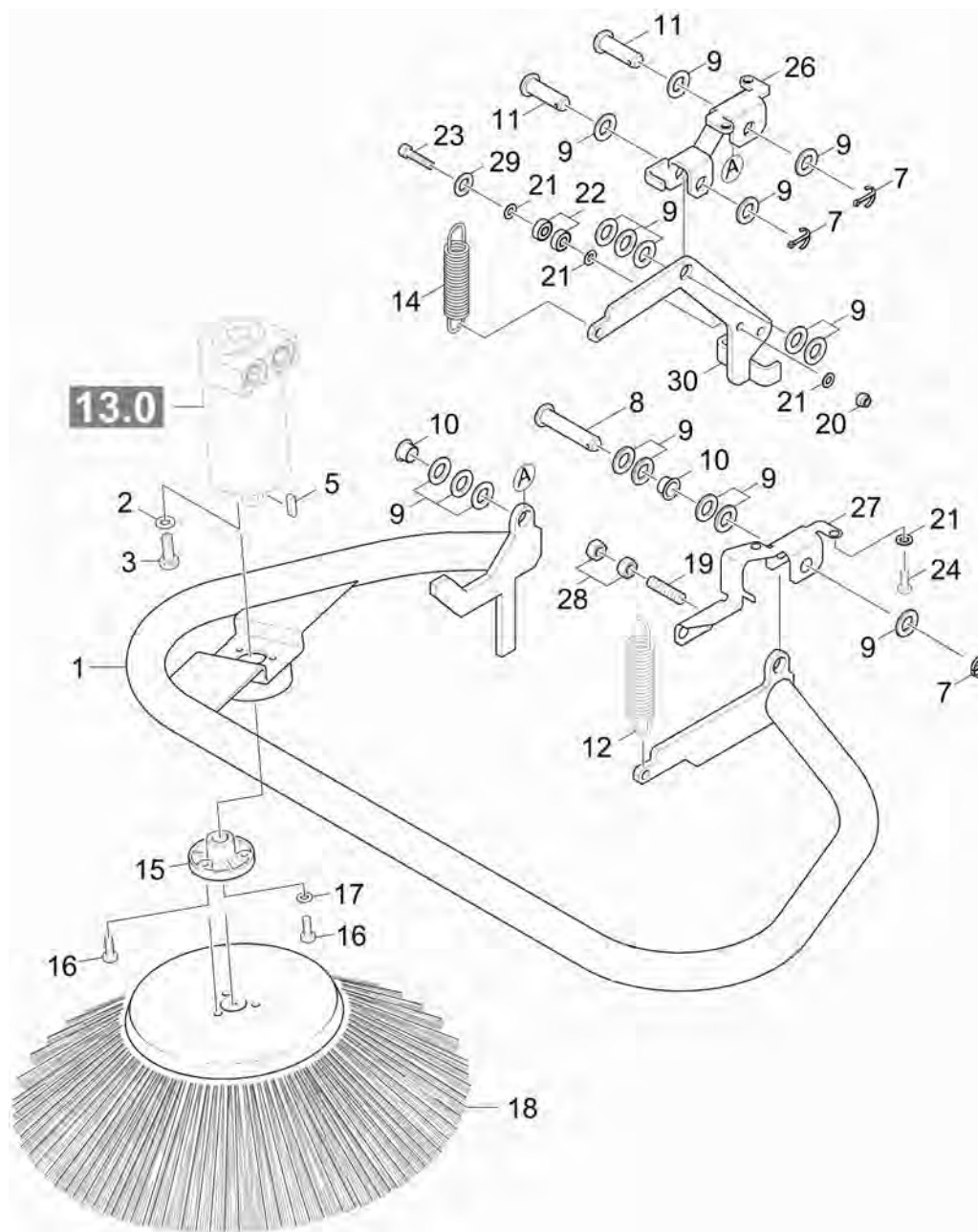

POS	Artikelnr.	Beschreibung	Anzahl	Einheit	Bemerkung
1	4.040-757.0	Rohr Buegel kpl.	1.000	ST	
2	7.312-003.0	Scheibe 6 -200HV-A3E ISO 7090	3.000	ST	
3	7.311-512.0	6kt-Mutter M 6-8-A2E ISO 7040	3.000	ST	
4	7.306-226.0	Schraube M 6x60-A2-70 DIN 7984	3.000	ST	
5	7.318-002.0	Passfeder 5x5x16 -C45R DIN 6885-1	1.000	ST	
7	7.316-352.0	Splint 4x36 -St-A2E ISO 1234	3.000	ST	
8	7.316-019.0	Bolzen B-16x75 -St-A2E ISO 2341	1.000	ST	
9	7.312-019.0	Scheibe 16-200HV-A3E ISO7090	17.000	ST	
10	6.437-484.0	Lagerbuchse	2.000	ST	
11	7.316-020.0	Bolzen B-16x50 -St-A2E ISO 2341	1.000	ST	
12	6.330-101.0	Zugfeder	1.000	ST	
13	5.059-829.0	Blechteil	1.000	ST	
14	6.330-200.0	Zugfeder	1.000	ST	
15	5.120-343.0	Nabe	1.000	ST	
16	7.306-031.0	Schraube M 6x16-A2-70 DIN 7984	4.000	ST	
17	7.312-260.0	Scheibe 6 -100HV-A3E ISO 7094	1.000	ST	
18	6.905-986.0	Seitenbesen	1.000	ST	
19	5.317-121.0	Bolzen	1.000	ST	
20	7.311-510.0	6kt-Mutter M 8-8-A2E ISO 7040	1.000	ST	
21	7.312-004.0	Scheibe 8 -200HV-A3E ISO 7090	6.000	ST	
22	7.401-149.0	Kugellager 608-2RS -Wälzl.St DIN 625	1.000	ST	
23	7.306-075.0	Zyl.Schr. M 8x 40-8.8-A2E ISO 4762	1.000	ST	Version 2
24	7.304-397.0	6kt-Schraube M8x20-8.8-A2E ISO 4017	4.000	ST	
26	5.061-890.0	Blechteil Halter rechts	1.000	ST	
27	5.059-731.0	Blechteil links (SP)	1.000	ST	
28	7.311-008.0	6kt-Mutter M12-8-A3E ISO 4032	2.000	ST	
29	5.094-399.0	Blechteil Scheibe	1.000	ST	
30	4.040-786.0	Hebel kpl.	1.000	ST	

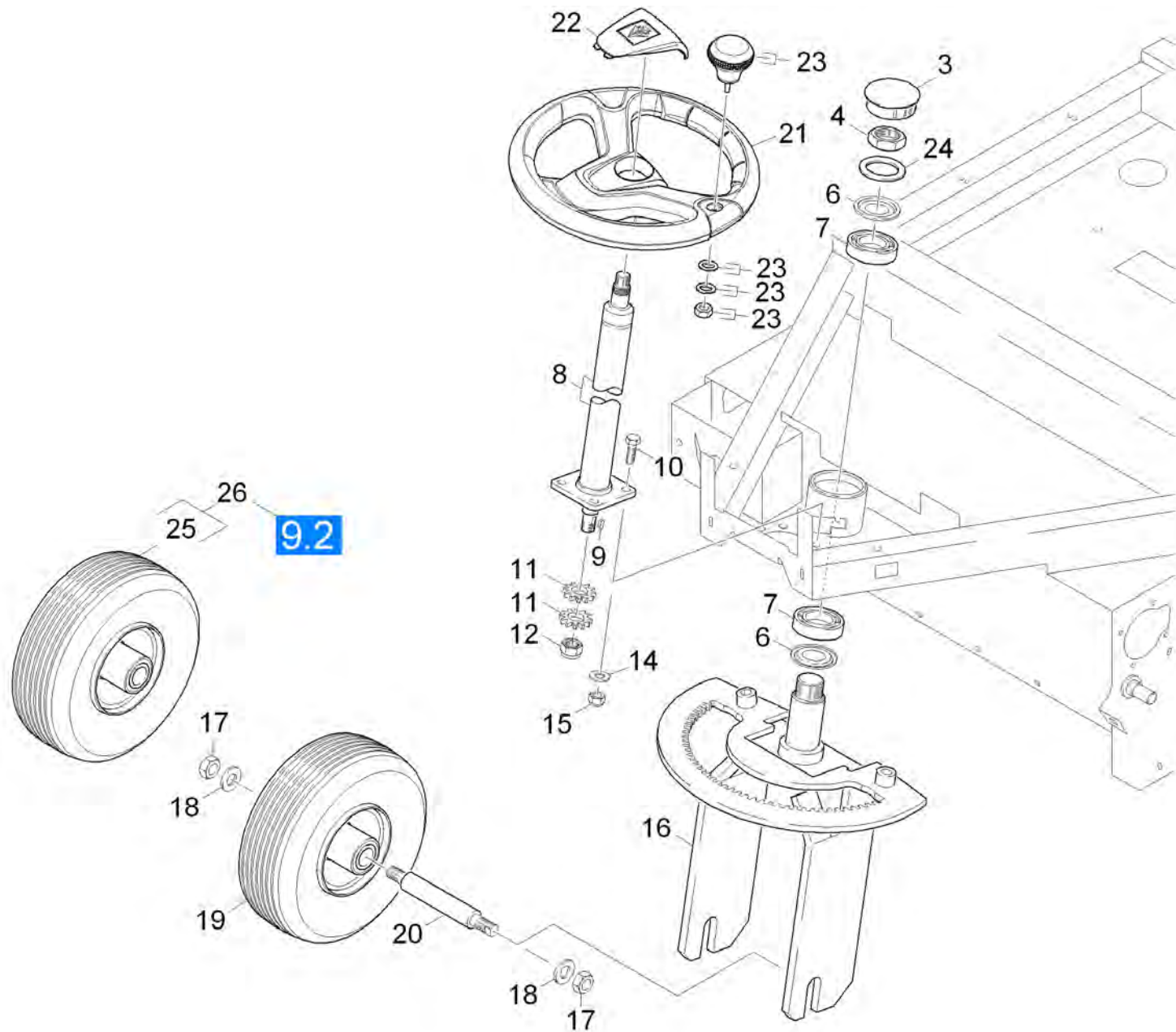

30 Lenkung

POS	Artikelnr.	Beschreibung	Anzahl	Einheit	Fußnotentext
3	6.368-215.0	Abdeckkappe	1.000	ST	
4	7.311-122.0	6kt-Mutter M24X1,5-22H-A2E DIN 936	1.000	ST	
6	6.401-263.0	Schleifring	2.000	ST	
7	6.401-260.0	Schraegkugellager	2.000	ST	
8	6.439-000.0	Lenksaeule	1.000	ST	
9	7.318-090.0	Passfeder A5x5x10-C45R DIN 6885	1.000	ST	
10	7.304-417.0	6kt-Schraube M10x30-8.8-A3E ISO 4017	4.000	ST	
11	5.352-000.0	Zahnrad	2.000	ST	
12	7.311-523.0	6kt-Mutter M16 -8-A2E ISO 7040	1.000	ST	
14	7.312-005.0	Scheibe 10-200HV-A3E ISO 7090	4.000	ST	
15	7.311-511.0	6kt-Mutter M10-8-A2E ISO 7040	4.000	ST	
16	4.520-120.0	Radgabel	1.000	ST	
17	7.311-426.0	6kt-Mutter M16-04-A2E ISO 10511	2.000	ST	
18	7.312-019.0	Scheibe 16-200HV-A3E ISO7090	2.000	ST	
19	6.435-846.0	Vorderrad	1.000	ST	
20	5.105-229.0	Achse	1.000	ST	
21	6.435-795.0	Lenkrad	1.000	ST	
22	6.640-353.0	Abdeckkappe Lenkrad KÄRCHER	1.000	ST	
23	6.640-354.0	Drehgriff	1.000	ST	
24	7.312-010.0	Scheibe 24 -200HV-A3E ISO 7090	1.000	ST	
25	6.435-319.0	Rad Vollgummi	1.000	ST	PANNENSICHER
26	7.777-999.0	Bevorratung eingestellt	1.000	ST	PANNENSICHER

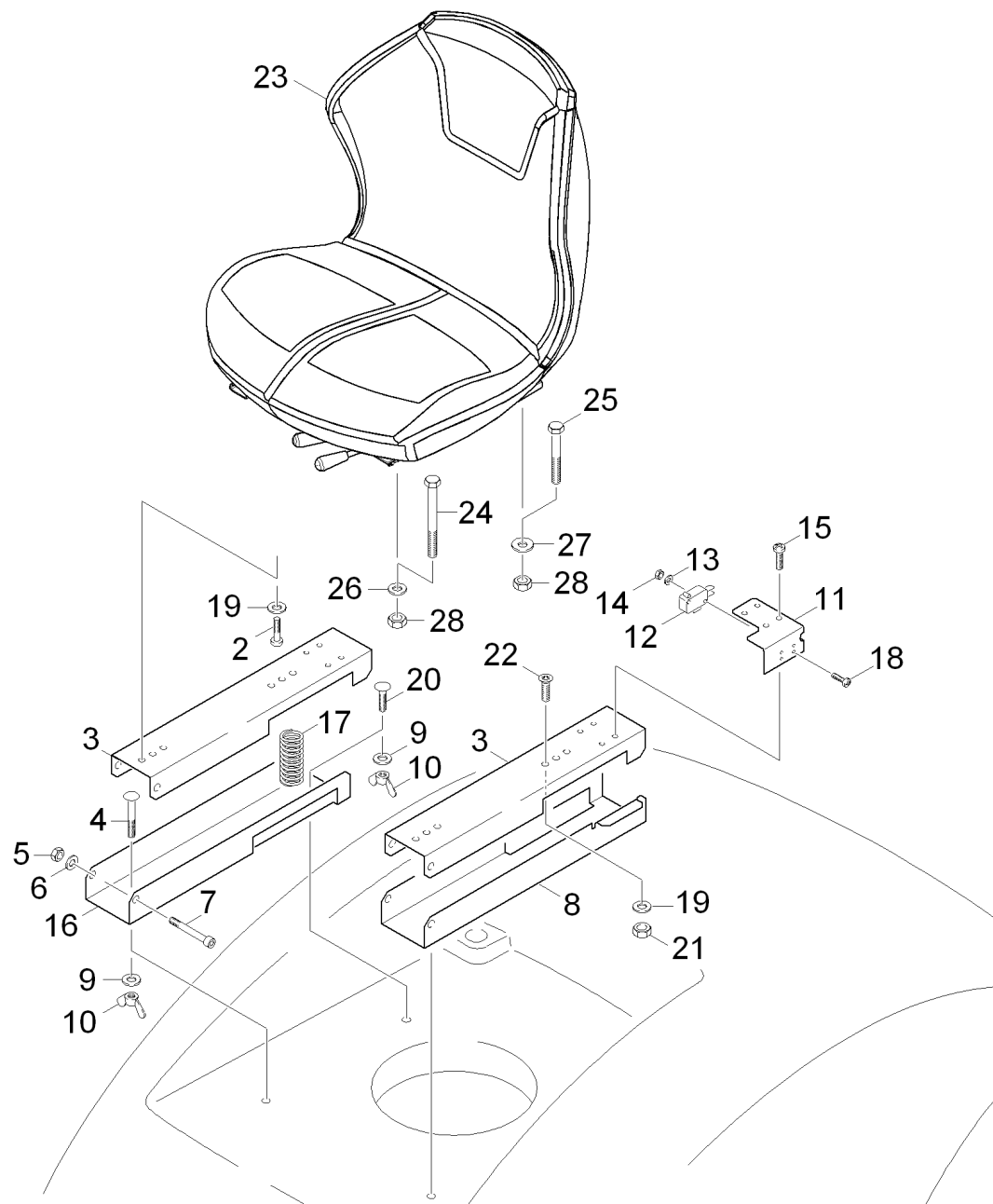

POS	Artikelnr.	Beschreibung	Anzahl	Einheit
2	7.306-218.0	Schraube M 8x16-A2-70 DIN 7984	4.000	ST
3	5.059-701.0	Blechteil oben (SP) Sitzschiene	2.000	ST
4	7.303-188.0	Fl.Rd.Schr. M10x65-ST-A0P DIN 603	4.000	ST
5	7.311-423.0	6kt-Mutter M10 -04-A2E ISO 10511	2.000	ST
6	7.312-005.0	Scheibe 10-200HV-A3E ISO 7090	2.000	ST
7	7.306-066.0	Zyl.Schr. M10x100- 8.8-A3E ISO 4762	2.000	ST
8	5.059-702.0	Blechteil unten (SP) Sitzschiene	1.000	ST
9	7.312-285.0	Scheibe 10 -200HV-A2E ISO7093-1	4.000	ST
10	7.310-004.0	Fluegelmutter M10-GT-A3E DIN 315	2.000	ST
11	5.059-700.0	Blechteil Mikroschalter (SP)	1.000	ST
12	6.631-854.0	Mikroschalter	1.000	ST
13	7.312-043.0	Scheibe 3-A2 ISO 7089	2.000	ST
14	7.311-000.0	6kt-Mutter M3 -8-A2E ISO 4032	2.000	ST
15	7.303-046.0	Schraube M6x12 -St-R3R (In6Rd)	4.000	ST
16	5.058-032.0	Blechteil Spritzschutz unten (SP)	1.000	ST
17	6.330-207.0	Feder	2.000	ST
18	7.306-406.0	Zyl.Schr. M3x16-4.8-A2E ISO 1207	2.000	ST
19	7.312-277.0	Scheibe 8-200HV-A2E ISO7093-1	4.000	ST
20	7.303-173.0	Fl.Rd.Schr. M10x45 -St-A0P DIN 603	2.000	ST
21	7.311-004.0	6kt-Mutter M8 -8-A3E ISO 4032	2.000	ST
22	7.305-013.0	Senkschraube M8x20-8.8-A2R ISO10642	1.000	ST
23	6.394-730.0	Sitz	1.000	ST
24	7.304-096.0	6kt-Schraube M8x60-8.8-A2E ISO 4014	2.000	ST
25	7.304-810.0	6kt-Schraube M 8x45-A4-70 ISO 4017	2.000	ST
26	6.997-241.0	Scheibe 8.4X20X2	2.000	ST
27	7.312-277.0	Scheibe 8-200HV-A2E ISO7093-1	2.000	ST
28	7.311-510.0	6kt-Mutter M 8-8-A2E ISO 7040	4.000	ST

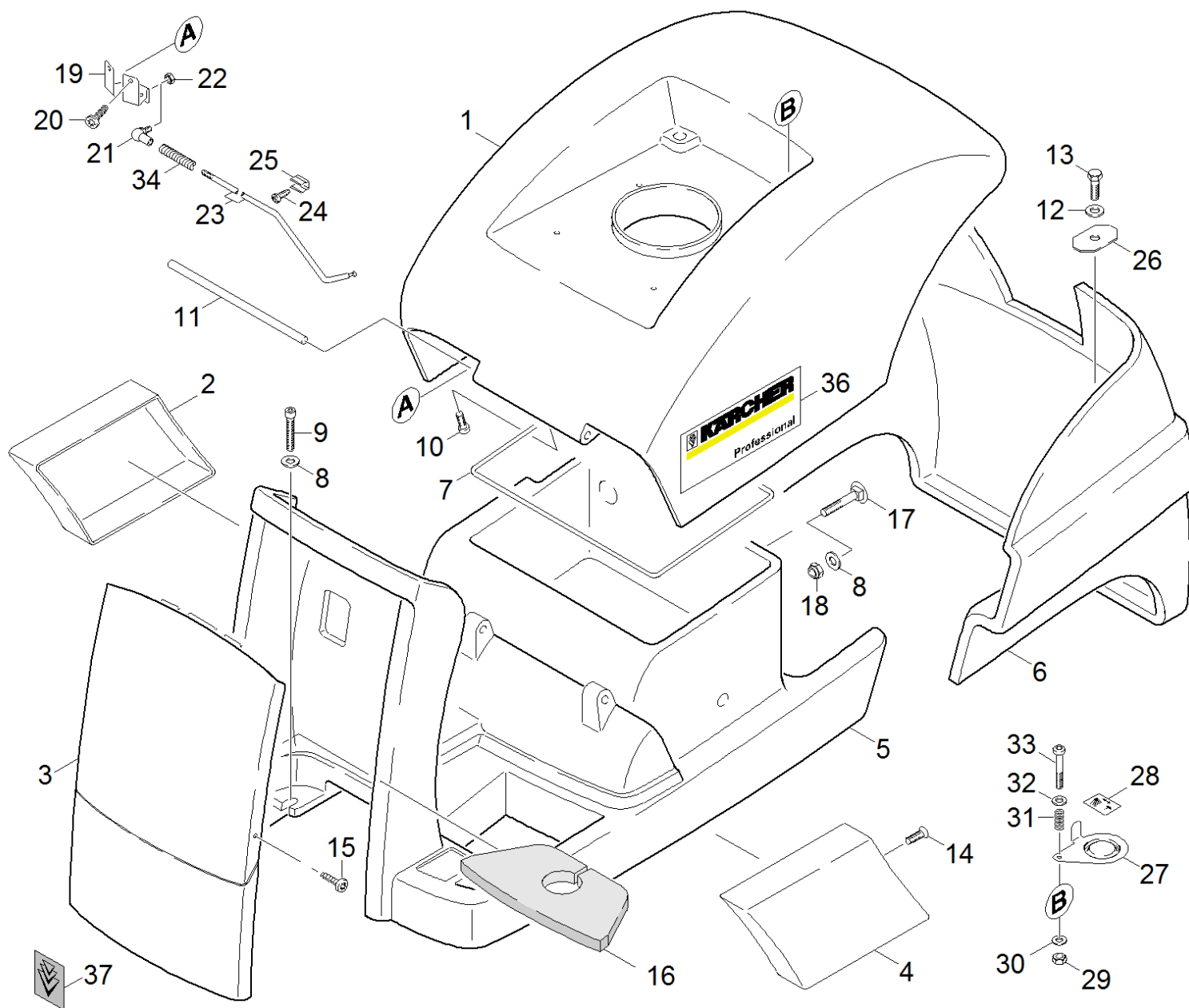

50 Verkleidung

POS	Artikelnr.	Beschreibung	Anzahl	Einheit	Fußnotentext
1	5.062-259.0	Haube Benzin	1.000	ST	
		Positionstext1: 1.280-105.0			
1	5.062-261.0	Haube Lpg	1.000	ST	
		Positionstext1: 1.280-107.0			
2	5.032-256.0	Verkleidung Seite rechts	1.000	ST	
3	5.033-642.0	Abdeckung vorne	1.000	ST	
4	5.032-257.0	Verkleidung Seite links	1.000	ST	
5	5.032-253.0	Filterkasten	1.000	ST	
6	5.032-255.0	Verkleidung Heck	1.000	ST	
7	6.366-043.0	Dichtungsprofil	1.000	M	ALS METERWARE BESTELLEN
8	7.312-277.0	Scheibe 8-200HV-A2E ISO7093-1	3.000	ST	
9	7.306-222.0	Zyl.Schr. M8x55 -A4-70 ISO 4762	1.000	ST	
10	6.303-125.0	Schraube 5x20-Sonder In6Rd+Spitze	2.000	ST	
11	5.100-403.0	Welle	1.000	ST	
12	7.312-261.0	Scheibe 8 -100HV-A3E ISO 7094	1.000	ST	
13	7.306-222.0	Zyl.Schr. M8x55 -A4-70 ISO 4762	1.000	ST	
14	6.304-152.0	Linsenschraube M6x20	6.000	ST	
16	5.365-278.0	Dichtung Schaumstoff	1.000	ST	
17	7.303-186.0	Fl.Rd.Schr. M8x40 -St-A0P DIN 603	3.000	ST	
18	7.311-427.0	6kt-Mutter M8 -04-A2E ISO 10511	3.000	ST	
19	5.058-291.0	Blechteil Stuetze Haube	1.000	ST	
20	7.303-112.0	Schraube 6x20 -10.9-R2R (In6Rd)	4.000	ST	
21	7.462-023.0	Winkelgelenk CS13 -A2E DIN 71802	1.000	ST	
22	7.311-004.0	6kt-Mutter M8 -8-A3E ISO 4032	1.000	ST	
23	5.107-242.0	Stange Stuetze Haube	1.000	ST	
24	7.303-092.0	Schraube 3x12 -10.9-R2R (K-In6Rd)	2.000	ST	
25	6.373-805.0	Schelle 8mm	1.000	ST	
26	5.007-756.0	Blech	4.000	ST	
27	5.058-437.0	Blechteil	1.000	ST	
28	5.391-053.0	Schild	1.000	ST	
29	7.311-421.0	6kt-Mutter M 5-04-A2E ISO 10511	1.000	ST	
30	7.312-002.0	Scheibe 5-200HV-A3E ISO 7090	1.000	ST	
31	5.332-076.0	Schraubenfeder	1.000	ST	

50 Verkleidung

POS	Artikelnr.	Beschreibung	Anzahl	Einheit	Fußnotentext
32	7.312-282.0	Scheibe 5 -A2 ISO 7093-1	1.000	ST	
33	7.306-188.0	Schraube M5x60 -A2-70 (In6Rd)	1.000	ST	
34	6.389-733.0	Schrumpfschlauch	1.000	M	ALS METERWARE BESTELLEN
36	5.392-874.0	Schild Seite Professional 355 x 133	1.000	ST	
37	5.394-087.0	Aufkleber Signet Gel 102x113	1.000	ST	

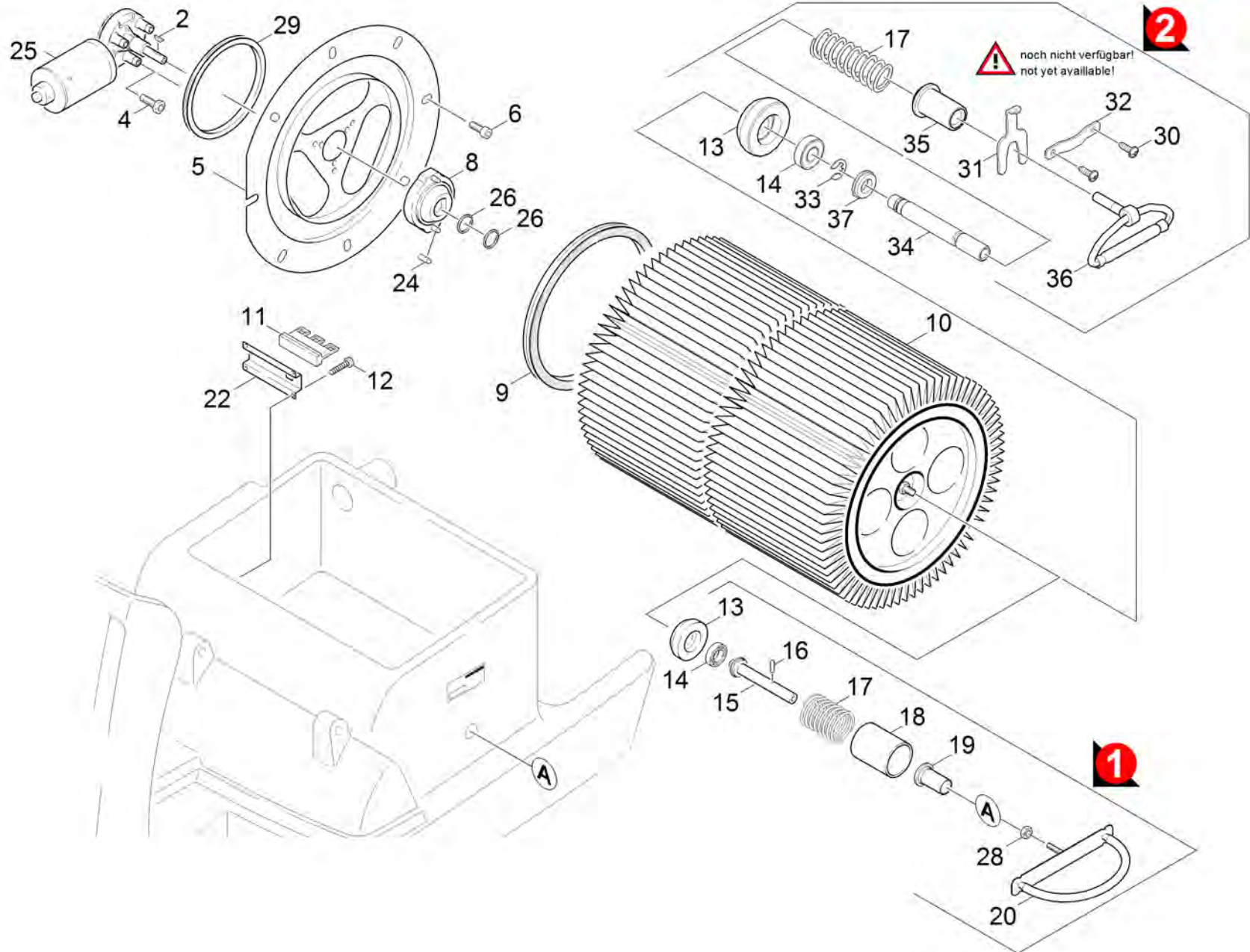

60 Filterkasten

POS	Artikelnr.	Beschreibung	Anzahl	Einheit	Bemerkung
2	7.318-204.0	Scheibenfeder 3x3,7-C45R DIN 6888	1.000	ST	
4	7.306-090.0	Schraube M6x16 -8.8-R3R (In6Rd)	3.000	ST	
5	4.122-115.0	Flansch kpl.	1.000	ST	
6	7.306-041.0	Zyl.Schr. M8x20 -8.8-A2E ISO 4762	8.000	ST	
8	4.474-029.0	Mitnehmer kpl.	1.000	ST	
9	6.362-950.0	Dichtring axial	1.000	ST	
10	6.414-532.0	Filterelement	1.000	ST	
11	5.031-344.0	Abstreifer	2.000	ST	
12	6.303-022.0	Linsenschraube 3,5x9,5-St-vz	8.000	ST	
13	5.474-017.0	Mitnehmer	1.000	ST	
14	6.401-363.0	Rillenkugellager	1.000	ST	
15	5.105-388.0	Achse	1.000	ST	
16	7.314-376.0	Zylinderstift 4x12-A-St ISO 8734	1.000	ST	
17	6.330-210.0	Druckfeder	1.000	ST	
18	6.390-917.0	Schlauch	1.000	ST	
19	5.110-904.0	Buchse	1.000	ST	
20	4.321-173.0	Griff	1.000	ST	Version 1
21	5.321-115.0	Griff	1.000	ST	
22	5.047-736.0	Blechteil	2.000	ST	
24	7.314-031.0	Spannstift 8x14-St ISO 8752	2.000	ST	
25	6.613-325.0	Getriebemotor 24V	1.000	ST	
26	7.343-003.0	Sicherungsring 12x1-Rf-St DIN 471	2.000	ST	
28	7.311-003.0	6kt-Mutter M6 -8-A2E ISO 4032	1.000	ST	
29	6.273-043.0	Dichtband Zellgummi 9x4	1.000	M	
29	2.273-000.0	Dichtband Zellgummi 9x4, 20m	1.000	ST	
30	7.303-107.0	Schraube 5x16 -10.9-P2R (K-In6Rd)	2.000	ST	
31	5.062-642.0	Sicherungsblech	1.000	ST	
32	5.062-643.0	Halterung Sicherungsblech	1.000	ST	
33	7.343-205.0	Sicherungsscheibe 9-St-A2E DIN 6799	1.000	ST	
34	5.105-012.0	Achse	1.000	ST	
35	5.110-010.0	Buchse	1.000	ST	
36	2.643-345.0	Griff Filterwechsel	1.000	ST	Version 2
37	5.110-011.0	Anschlag Feder	1.000	ST	

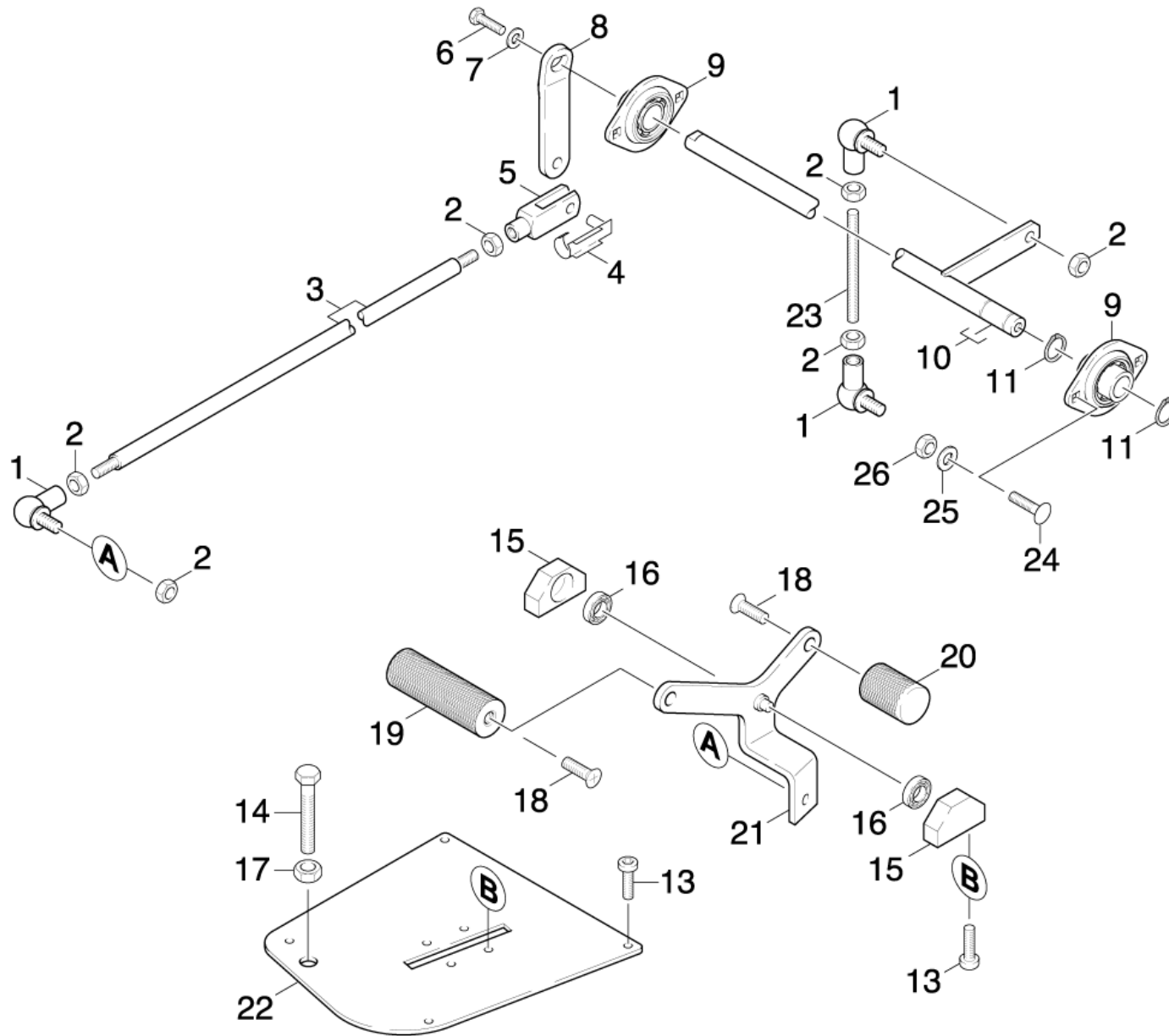

70 Pedal

POS	Artikelnr.	Beschreibung	Anzahl	Einheit	Bemerkung
1	7.462-023.0	Winkelgelenk CS13 -A2E DIN 71802	3.000	ST	
2	7.311-004.0	6kt-Mutter M8 -8-A3E ISO 4032	4.000	ST	
3	5.107-236.0	Stange	1.000	ST	
4	6.316-054.0	Bolzen	1.000	ST	
5	7.462-013.0	Gabelkopf G8x32 -St-A2E DIN71752	1.000	ST	
6	7.304-536.0	6kt-Schraube M 6x20-A4-70 ISO 4017	1.000	ST	
7	7.312-260.0	Scheibe 6 -100HV-A3E ISO 7094	2.000	ST	
8	5.004-947.0	Lasche	1.000	ST	
9	6.401-242.0	Flanschlager	2.000	ST	
10	4.100-199.0	Welle kpl.	1.000	ST	
11	7.343-004.0	Sicherungsring 15x1-FST-PHR DIN 471	2.000	ST	
13	7.306-089.0	Schraube M6x12 -8.8-R2R (In6Rd)	8.000	ST	
14	7.304-514.0	6kt-Schraube M10x50-A2-70 ISO 4017	1.000	ST	
15	5.251-047.0	Lagerbock	2.000	ST	
16	7.401-174.0	Kugellager 688-2Z -Wälzl.St DIN 625	2.000	ST	
17	7.311-006.0	6kt-Mutter M10 -8-A3E ISO 4032	1.000	ST	
18	7.306-063.0	Zyl.Schr. M10x30-8.8-A3E ISO4762	2.000	ST	
19	5.321-702.0	Griff	1.000	ST	
20	5.321-701.0	Griff	1.000	ST	
21	4.481-267.0	Hebel kpl.	1.000	ST	
22	4.002-131.0	Grundplatte kpl.	1.000	ST	
23	5.309-089.0	Gewindestange Anhebung Kehrwalze	1.000	ST	L=90mm
23	5.010-265.0	Gewindebolzen Verstellung B 60 W	1.000	ST	L=160mm
24	7.303-139.0	Fl.Rd.Schr. M6x20 -A2 DIN 603	4.000	ST	
25	7.312-003.0	Scheibe 6 -200HV-A3E ISO 7090	4.000	ST	

80 Kehrwalzenkasten

POS	Beschreibung	Anzahl	Einheit
81	Kehrbehälter	1.000	ST
82	Kehrwalze	1.000	ST

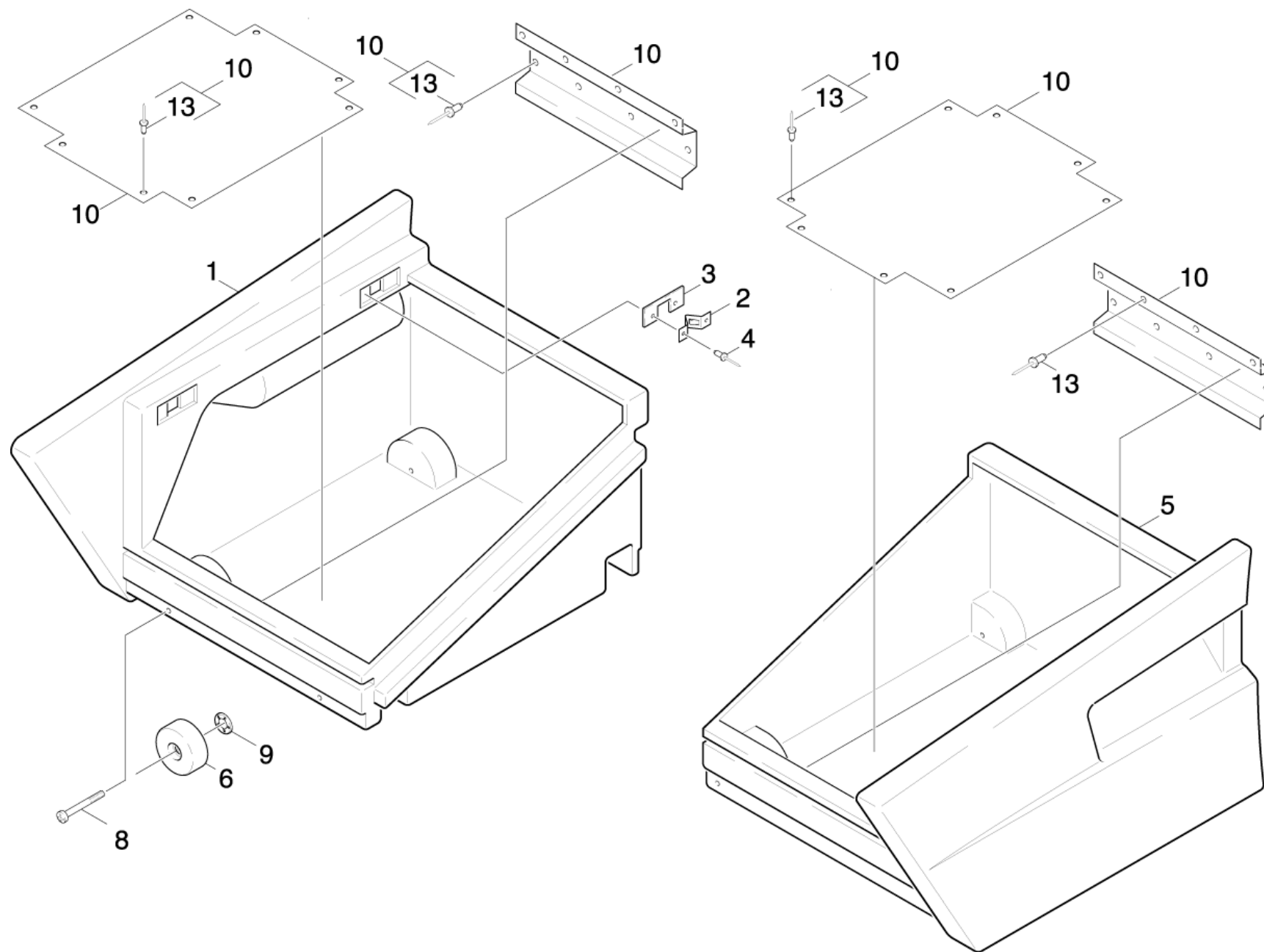

81 Kehrbehälter

POS	Artikelnr.	Beschreibung	Anzahl	Einheit
1	5.032-252.0	Kehrbehälter rechts	1.000	ST
2	6.330-149.0	Feder	4.000	ST
3	5.007-609.0	Blech	4.000	ST
4	7.315-013.0	Blindniet 3,2x18 -Al/A2 ISO 15983	8.000	ST
5	5.032-251.0	Kehrbehälter links	1.000	ST
6	5.515-068.0	Rad	8.000	ST
8	7.306-268.0	Schraube M6x70 -8.8-R3R (In6Rd)	8.000	ST
9	6.343-169.0	Schnellbefestiger	8.000	ST
10	2.882-597.0	UBS Kehrbehälter KM 100/100 R	1.000	ST
13	7.315-007.0	Blindniet 3,2x10 -Al/A2 ISO 15983	36.000	ST

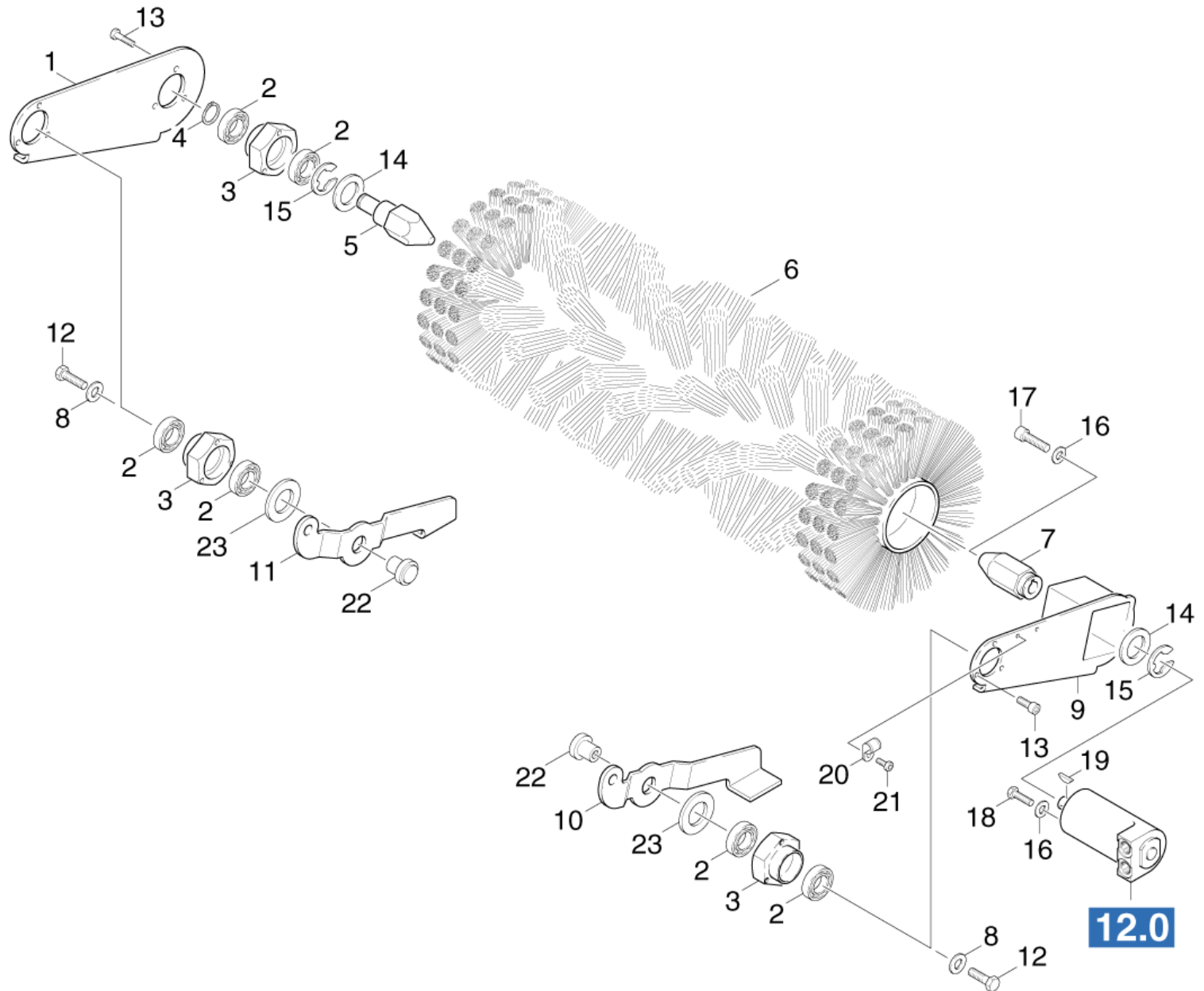

82 Kehrwalze

POS	Artikelnr.	Beschreibung	Anzahl	Einheit
1	5.059-664.0	Blechteil Schwinge	1.000	ST
2	7.401-105.0	Kugellager 6003-2RS Wälzl.St DIN 625	6.000	ST
3	5.122-189.0	Flansch Guss	3.000	ST
4	7.343-005.0	Sicherungsring 16x1-FST-PHR DIN 471	3.000	ST
5	5.474-032.0	Mitnehmer Kehrwalze	1.000	ST
6	6.906-375.0	Kehrwalze	1.000	ST
7	5.474-033.0	Mitnehmer Hydraulik	1.000	ST
8	7.312-289.0	Scheibe 8 -A2 ISO 7093-1	2.000	ST
9	4.040-028.0	Blechteil Schwinge Hydraulik	1.000	ST
10	5.059-716.0	Blechteil links	1.000	ST
11	5.059-715.0	Blechteil rechts	1.000	ST
12	7.304-395.0	6kt-Schraube M8x16-8.8-A2E ISO 4017	2.000	ST
13	7.303-047.0	Schraube M6x16 -St-R3R (In6Rd)	9.000	ST
14	7.312-025.0	Scheibe 27-200HV-A3E ISO7090	2.000	ST
15	7.343-045.0	Sicherungsscheibe 24-FST-A2E DIN 6799	2.000	ST
16	7.312-003.0	Scheibe 6 -200HV-A3E ISO 7090	4.000	ST
17	7.306-024.0	Zyl.Schr. M6x30 -8.8-A2E ISO4762	1.000	ST
18	7.304-521.0	6kt-Schraube M 6x16-A4-70 ISO 4017	3.000	ST
19	7.318-002.0	Passfeder 5x5x16 -C45R DIN 6885-1	1.000	ST
20	6.373-406.0	Rohrschelle 13	2.000	ST
21	7.303-032.0	Schraube M4x12 -St-R2R (In6Rd)	2.000	ST
22	5.112-717.0	Buchse	2.000	ST
23	5.116-079.0	Scheibe	2.000	ST

90 Antrieb Motor Benzin GX270UT2

POS	Beschreibung	Anzahl	Einheit	Bemerkung
91	Motor	1.000	ST	
92	Fahrantrieb	1.000	ST	
93	Gebraese	1.000	ST	
94	Antrieb	1.000	ST	
95	Einzelteile Motor Honda GX270UT2	1.000	ST	Version 2

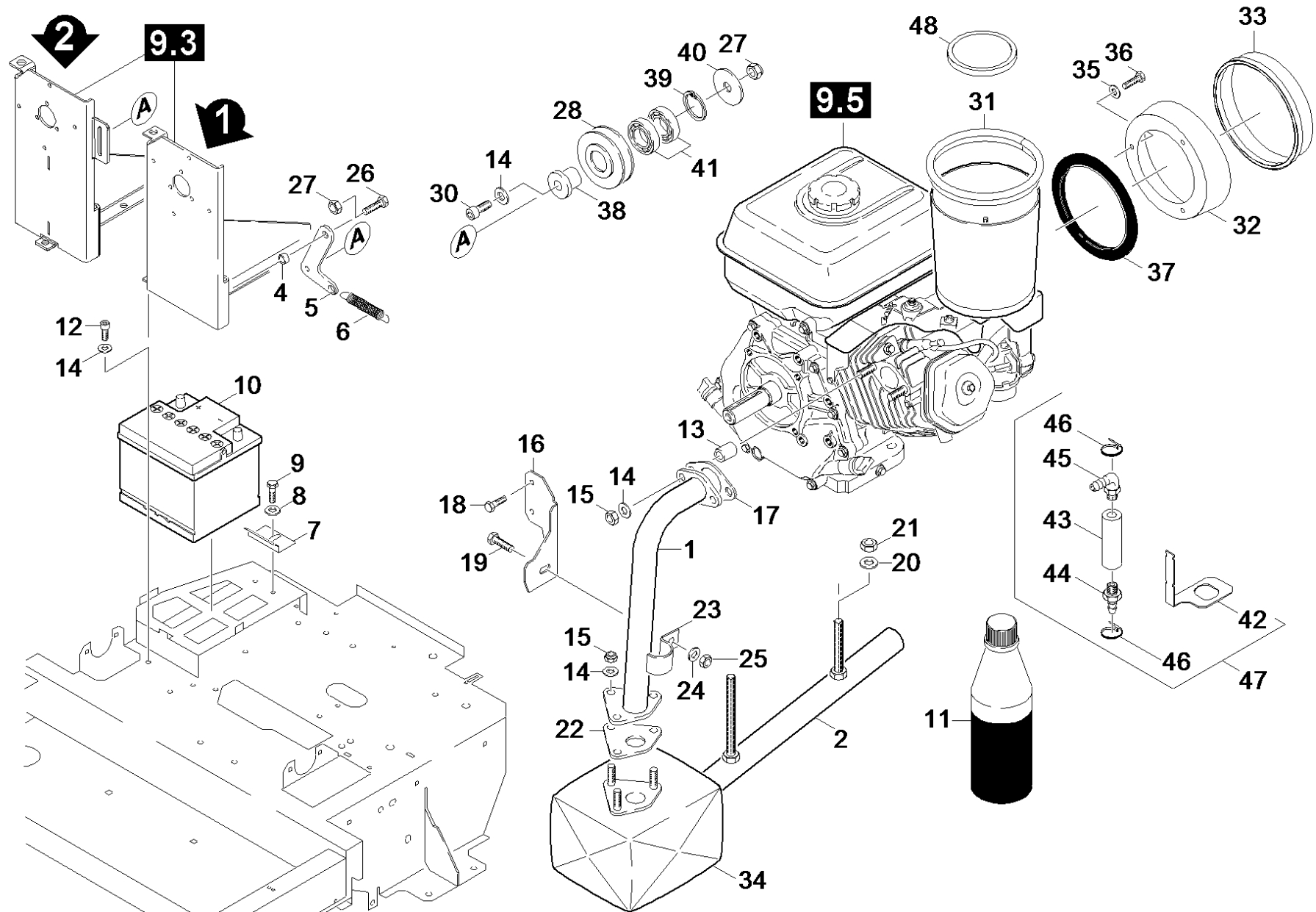

91 Motor

POS	Artikelnr.	Beschreibung	Anzahl	Einheit
1	4.462-137.0	Kruemmer kpl. B	1.000	ST
2	4.462-140.0	Auspuff	1.000	ST
4	5.112-610.0	Buchse	1.000	ST
5	5.059-721.0	Blechteil	1.000	ST
6	6.330-197.0	Zugfeder	1.000	ST
7	5.047-460.0	Blechteil	1.000	ST
8	7.312-292.0	Scheibe 6 -A2 ISO 7093-1	1.000	ST
9	7.304-382.0	6kt-Schraube M 6x12-8.8-A2E ISO 4017	1.000	ST
10	7.654-001.0	Batterie 50Ah 12V	1.000	ST
11	6.288-050.0	Motorenoel 1L	1.000	ST
12	7.306-041.0	Zyl.Schr. M8x20 -8.8-A2E ISO 4762	1.000	ST
13	5.110-651.0	Huelse	2.000	ST
14	7.312-004.0	Scheibe 8 -200HV-A3E ISO 7090	7.000	ST
15	7.311-004.0	6kt-Mutter M8 -8-A3E ISO 4032	8.000	ST
16	5.059-991.0	Blechteil	1.000	ST
17	6.491-605.0	Dichtung -HONDA 18333ZE3800	1.000	ST
18	6.304-033.0	Schraube 5/16-24UNF	1.000	ST
19	7.304-435.0	6kt-Schraube M12x30-8.8-A3E ISO 4017	1.000	ST
20	7.312-285.0	Scheibe 10 -200HV-A2E ISO7093-1	2.000	ST
21	7.311-006.0	6kt-Mutter M10 -8-A3E ISO 4032	2.000	ST
22	6.491-606.0	Dichtung -HONDA 18381ZE2800	1.000	ST
23	7.373-030.0	Rohrschelle 28,5-ST-A2E DIN 1592	1.000	ST
24	7.312-287.0	Scheibe 12-200HV-A2E ISO7093-1	1.000	ST
25	7.311-008.0	6kt-Mutter M12-8-A3E ISO 4032	2.000	ST
26	7.304-399.0	6kt-Schraube M 8x25-8.8-A2E ISO 4017	3.000	ST
27	7.311-510.0	6kt-Mutter M 8-8-A2E ISO 7040	6.000	ST
28	5.100-409.0	Spannrolle XPA 72	1.000	ST
29	7.312-289.0	Scheibe 8 -A2 ISO 7093-1	1.000	ST
30	7.304-404.0	6kt-Schraube M8x40-8.8-A2E ISO 4017	1.000	ST
31	6.365-374.0	Dichtungsprofil	1.000	M
32	5.032-347.0	Luftkanal	1.000	ST
33	6.365-413.0	Dichtungsprofil	1.000	M
34	6.491-633.0	Auspufftopf	1.000	ST

91 Motor

POS	Artikelnr.	Beschreibung	Anzahl	Einheit
35	7.312-260.0	Scheibe 6 -100HV-A3E ISO 7094	3.000	ST
36	7.306-089.0	Schraube M6x12 -8.8-R2R (In6Rd)	3.000	ST
37	6.273-043.0	Dichtband Zellgummi 9x4	1.000	M
37	2.273-000.0	Dichtband Zellgummi 9x4, 20m	1.000	ST
38	5.100-231.0	Buchse	1.000	ST
39	7.343-167.0	Sicherungsring 35x1,5-FST-BR DIN 472	1.000	ST
40	7.312-277.0	Scheibe 8-200HV-A2E ISO7093-1	1.000	ST
41	7.401-022.0	Kugellager 16003-2RS-WST PREISW. DIN 625	2.000	ST
42	5.062-436.0	Blechteil Halter Abscheider	1.000	ST
43	5.123-252.0	Rohr Kraftstoff Abscheider	1.000	ST
44	6.123-266.0	Schlauchnippel d4/R1/4"	1.000	ST
45	6.123-267.0	Schlauchnippel 90° d4/R1/4"	1.000	ST
46	6.641-464.0	Kabelbinder	2.000	ST
47	2.643-041.0	UBS Abscheider Benzin	1.000	ST
48	5.062-584.0	Distanzring	1.000	ST

2 Auspuff (4.462-140.0)

POS	Artikelnr.	Beschreibung	Anzahl	Einheit
2	7.304-062.0	6kt-Schraube M10x70-A2-70 ISO 4017	1.000	ST
3	7.304-053.0	6kt-Schraube M10x110 -A2-70 ISO 4017	1.000	ST

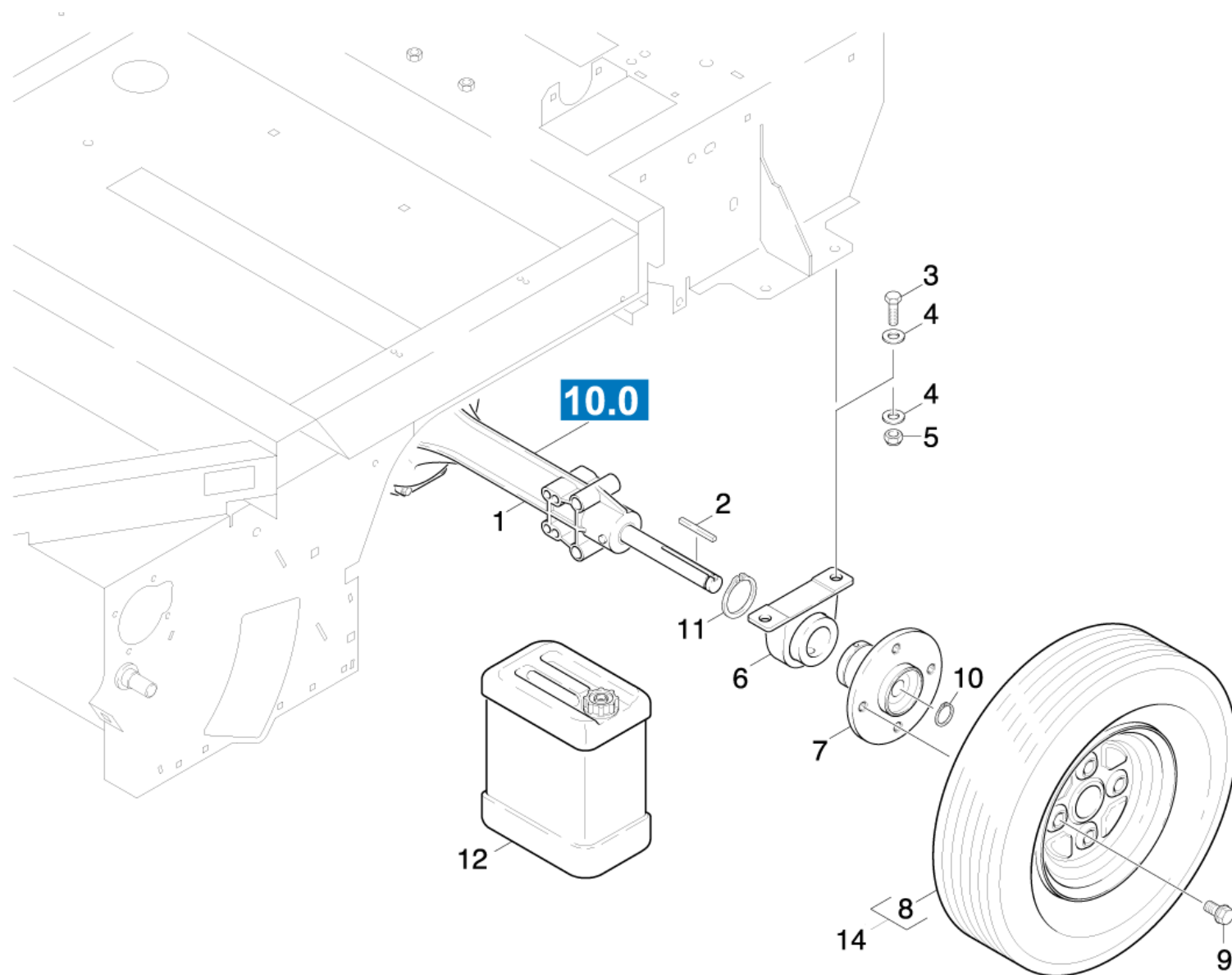

92 Fahrtrieb

POS	Artikelnr.	Beschreibung	Anzahl	Einheit	Fußnotentext
1	6.454-130.0	Getriebe Achse	1.000	ST	
2	6.491-741.0	Passfeder	2.000	ST	
6	6.401-355.0	Flanschlager	2.000	ST	
7	5.122-398.0	Flansch	2.000	ST	
8	6.435-833.0	Rad kpl.	2.000	ST	
8	6.435-439.0	Rad Vollgummi	2.000	ST	PANNENSICHER
9	6.997-362.0	Radschraube G12x21-10.9	8.000	ST	
10	7.343-064.0	Sicherungsring 19x1 -Rf-St DIN 472	2.000	ST	
11	7.343-011.0	Sicherungsring 35x1,5-FST-VZ DIN 471	2.000	ST	
12	4.070-489.0	Universal Oel SAE 20W50	1.000	ST	
14	7.777-999.0	Bevorratung eingestellt	1.000	ST	PANNENSICHER

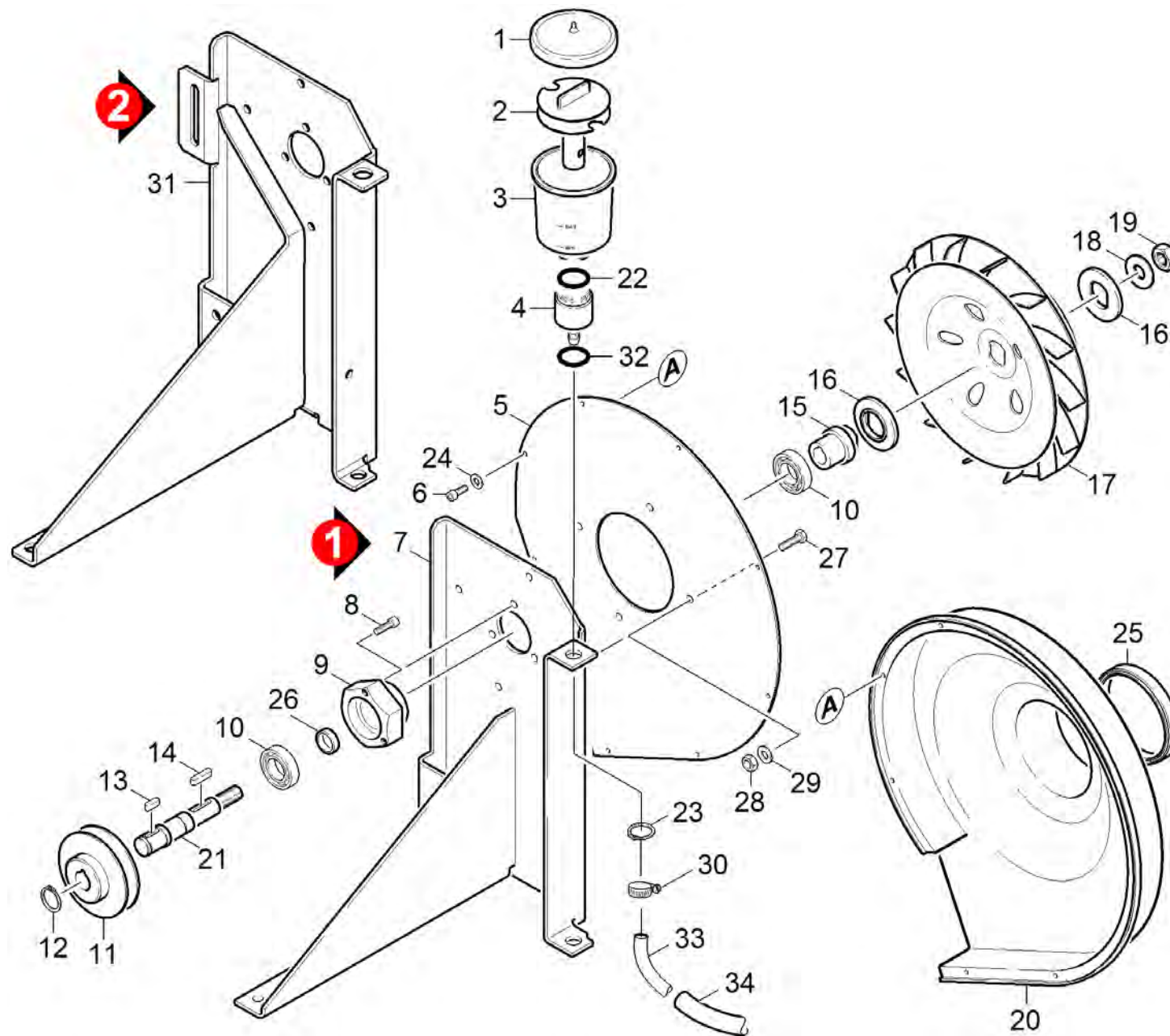

93 Geblaese

POS	Artikelnr.	Beschreibung	Anzahl	Einheit	Bemerkung	Fußnotentext
1	5.063-471.0	Deckel	1.000	ST		
2	5.030-389.0	Formteil	1.000	ST		
3	5.070-048.0	Behaelter	1.000	ST		
4	5.409-368.0	Nippel	1.000	ST		
5	5.059-806.0	Blechteil	1.000	ST		
6	7.303-030.0	Schraube M4x8 -St-P2R (In6Rd)	9.000	ST		
7	4.040-085.0	Blechteil kpl.	1.000	ST	VERSION 1	
8	7.303-047.0	Schraube M6x16 -St-R3R (In6Rd)	3.000	ST		
9	5.122-189.0	Flansch Guss	1.000	ST		
10	7.401-105.0	Kugellager 6003-2RS Wälzl.St DIN 625	2.000	ST		
11	5.625-492.0	Keilriemenscheibe	1.000	ST		
12	7.343-006.0	Sicherungsring 17x1-St-ph DIN 471	1.000	ST		
13	7.318-079.0	Passfeder A 5x5x25-C45R DIN 6885	1.000	ST		
14	7.318-070.0	Passfeder 5x5x20-C45R DIN 6885-1	1.000	ST		
15	5.112-651.0	Buchse Antrieb Geblaese	1.000	ST		
16	6.312-046.0	Distanzscheibe	2.000	ST		
17	6.484-326.0	Geblaeserad D=222mm	1.000	ST		
18	7.312-287.0	Scheibe 12-200HV-A2E ISO7093-1	1.000	ST		
19	7.311-429.0	6kt-Mutter M12-04-A2E ISO 10511	1.000	ST		
20	6.961-164.0	Gehaeuse	1.000	ST		
21	5.100-413.0	Welle Geblaese	1.000	ST		
22	6.362-168.0	O-Ring 22,3 X 2,4-NBR 70	1.000	ST		
23	7.343-031.0	Sicherungsring 14x1-FST-PHR DIN 471	1.000	ST		
24	7.312-281.0	Scheibe 4 -200HV-A2E ISO7093-1	8.000	ST		
25	6.363-168.0	Dichtung	2.000	ST		
26	5.110-913.0	Buchse	1.000	ST		
27	7.304-521.0	6kt-Schraube M 6x16-A4-70 ISO 4017	4.000	ST		
28	7.311-425.0	6kt-Mutter M6 -04-A2E ISO 10511	4.000	ST		
29	7.312-003.0	Scheibe 6 -200HV-A3E ISO 7090	4.000	ST		
30	6.388-537.0	Schlauchschelle	2.000	ST		
31	4.040-755.0	Blechteil Halter Geblaese	1.000	ST	VERSION 2	
32	6.362-858.0	O-Ring 11,0 X 1,5	1.000	ST		
33	6.389-610.0	Schlauch	1.000	M		ALS METERWARE BESTELLEN

93 Geblaese

POS	Artikelnr.	Beschreibung	Anzahl	Einheit	Bemerkung	Fußnotentext
34	6.390-219.0	Schutzschlauch	1.000	M		
100	2.850-925.0	UBS Keilriemen KM100/100	1.000	ST		

100 UBS Keilriemen KM100/100 (2.850-925.0)

POS	Artikelnr.	Beschreibung	Anzahl	Einheit
1	4.040-755.0	Blechteil Halter Geblaese	1.000	ST
2	5.625-492.0	Keilriemenscheibe	1.000	ST
3	6.348-410.0	Keilriemen XPA 757	1.000	ST
4	5.625-493.0	Keilriemenscheibe	1.000	ST
5	5.100-409.0	Spannrolle XPA 72	1.000	ST
6	7.401-022.0	Kugellager 16003-2RS-WST PREISW. DIN 625	2.000	ST
7	7.311-510.0	6kt-Mutter M 8-8-A2E ISO 7040	1.000	ST
8	7.312-277.0	Scheibe 8-200HV-A2E ISO7093-1	1.000	ST
9	7.343-167.0	Sicherungsring 35x1,5-FST-BR DIN 472	1.000	ST
10	5.100-231.0	Buchse	1.000	ST
11	7.304-404.0	6kt-Schraube M8x40-8.8-A2E ISO 4017	1.000	ST
12	7.312-004.0	Scheibe 8 -200HV-A3E ISO 7090	1.000	ST

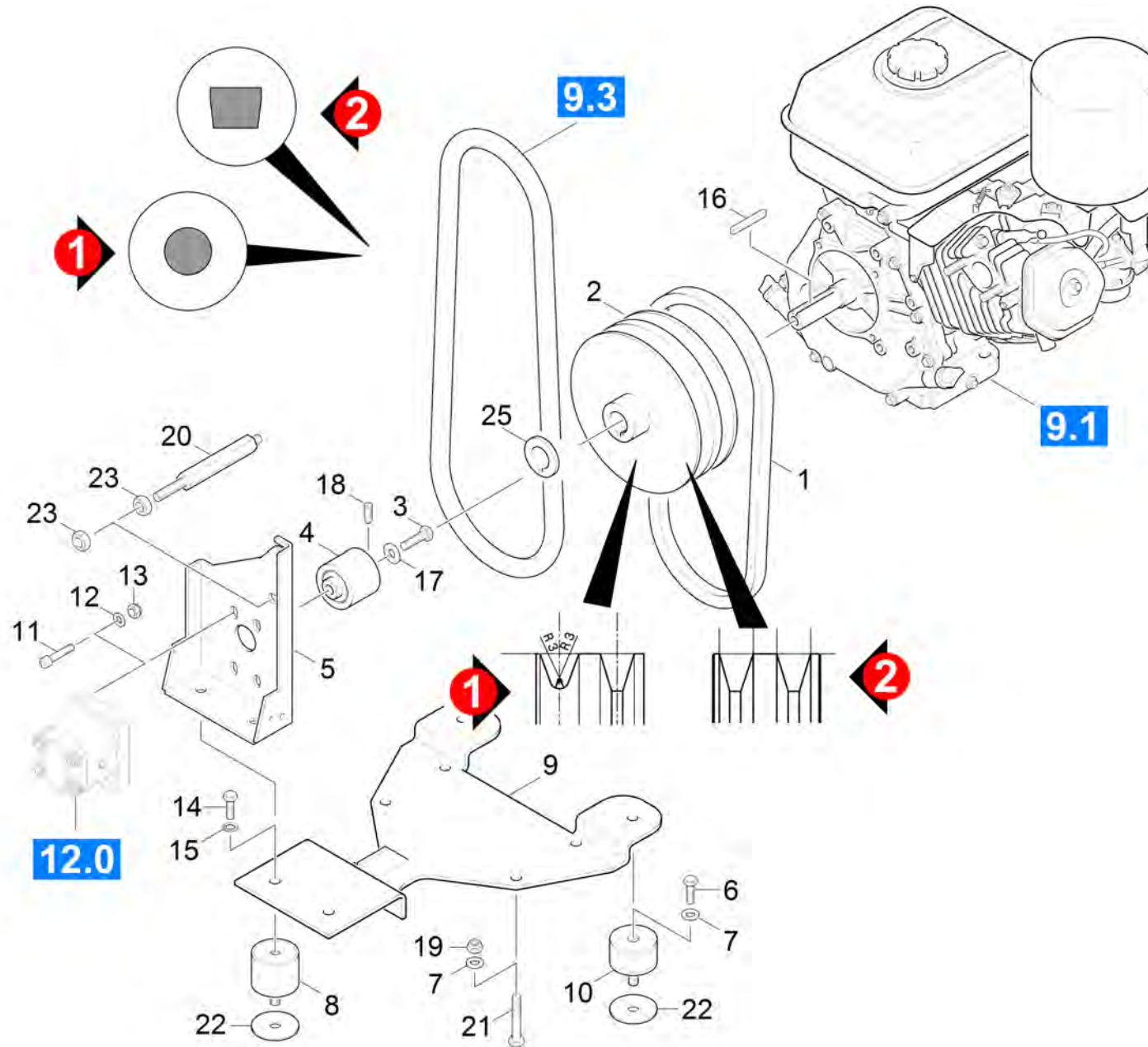

94 Antrieb

POS	Artikelnr.	Beschreibung	Anzahl	Einheit	Werknummer ab	Werknummer bis	Bemerkung
1	6.348-390.0	Keilriemen XPA 882	1.000	ST			
2	5.625-493.0	Keilriemenscheibe	1.000	ST			VERSION 2
2	5.625-404.0	Riemenscheibe Motor	1.000	ST			VERSION 1
3	6.304-073.0	6kt-Schr. 7/16-20UNF-8.8-A2E ISO 4017	1.000	ST			
4	6.463-000.0	Kupplung MOTOR-HY PUMPE	1.000	ST			
5	5.059-629.0	Blechteil Rahmen	1.000	ST		11045	
5	5.057-473.0	Blechteil Rahmen Motorhalter	1.000	ST	11046		
6	7.304-410.0	6kt-Schraube M10x16-8.8-A3E ISO 4017	2.000	ST			
7	7.312-005.0	Scheibe 10-200HV-A3E ISO 7090	2.000	ST			
8	6.339-127.0	Gummipuffer	2.000	ST			
9	4.040-083.0	Blechteil Traeger Motor	1.000	ST			
10	6.339-170.0	Gummipuffer	2.000	ST			
11	7.306-129.0	Schraube M6x40 -8.8-R3R (In6Rd)	4.000	ST			
12	7.312-260.0	Scheibe 6 -100HV-A3E ISO 7094	4.000	ST			
13	7.311-512.0	6kt-Mutter M 6-8-A2E ISO 7040	4.000	ST			
14	7.304-414.0	6kt-Schraube M10x20-8.8-A3E ISO 4017	2.000	ST			
15	7.312-285.0	Scheibe 10 -200HV-A2E ISO7093-1	2.000	ST			
16	6.905-999.0	Passfeder	1.000	ST			
17	6.312-001.0	Scheibe 11,5 -200HV	1.000	ST			
18	7.307-350.0	Gew.Stift M 8X 8-45H ISO 4029	1.000	ST			
19	7.311-511.0	6kt-Mutter M10-8-A2E ISO 7040	4.000	ST			
20	5.055-304.0	Strebe	1.000	ST			
21	7.304-426.0	6kt-Schraube M10x45-8.8-A3E ISO 4017	4.000	ST			
22	5.116-060.0	Scheibe	2.000	ST			
23	7.311-006.0	6kt-Mutter M10 -8-A3E ISO 4032	2.000	ST			
24	6.348-381.0	Rundriemen D10	1.000	ST			VERSION 1

94 Antrieb

POS	Artikelnr.	Beschreibung	Anzahl	Einheit	Werknummer ab	Werknummer bis	Bemerkung
24	6.348-410.0	Keilriemen XPA 757	1.000	ST			VERSION 2
25	5.007-446.0	Blech Distanzstueck Kurbelwelle	1.000	ST			

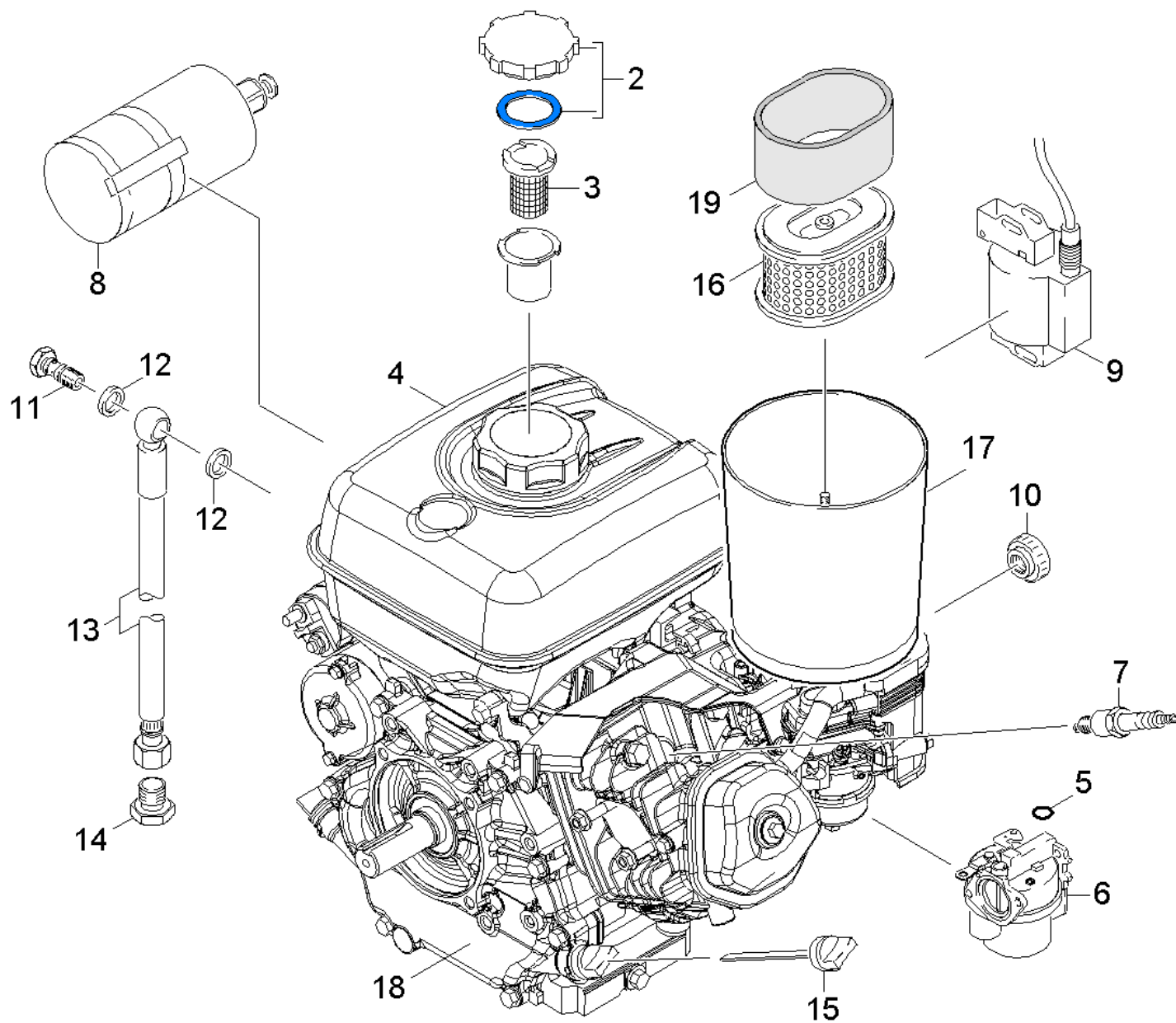

95 Einzelteile Motor Honda GX270UT2

POS	Artikelnr.	Beschreibung	Anzahl	Einheit
2	6.491-347.0	Tankdeckel kpl.	1.000	ST
3	6.491-514.0	Filter	1.000	ST
4	6.491-599.0	Tank Benzin kpl.	1.000	ST
5	6.362-079.0	O-Ring 18,0 X 2,5	1.000	ST
6	6.491-621.0	Vergaser kpl.	1.000	ST
7	6.618-090.0	Zuendkerze	1.000	ST
8	6.491-600.0	Anlasser kpl. nur fuer Ersatz	1.000	ST
9	6.491-622.0	Zuendspule	1.000	ST
10	7.777-999.0	Bevorratung eingestellt	4.000	ST
11	7.386-344.0	Hohlschraube 8-3-St-A3L DIN 7643	1.000	ST
12	7.362-004.0	Dichtring A12x15,5 -Cu DIN 7603	2.000	ST
13	6.390-144.0	Schlauch ND	1.000	ST
14	6.385-789.0	Verschlusschraube	1.000	ST
15	6.491-596.0	Oelmessstab	1.000	ST
16	6.491-566.0	Luftfilter	1.000	ST
17	4.421-948.0	Luftkanal kpl.	1.000	ST
18	6.491-973.0	Motor Honda GX 270	1.000	ST
19	6.491-720.0	Einsatz Luftfilter	1.000	ST

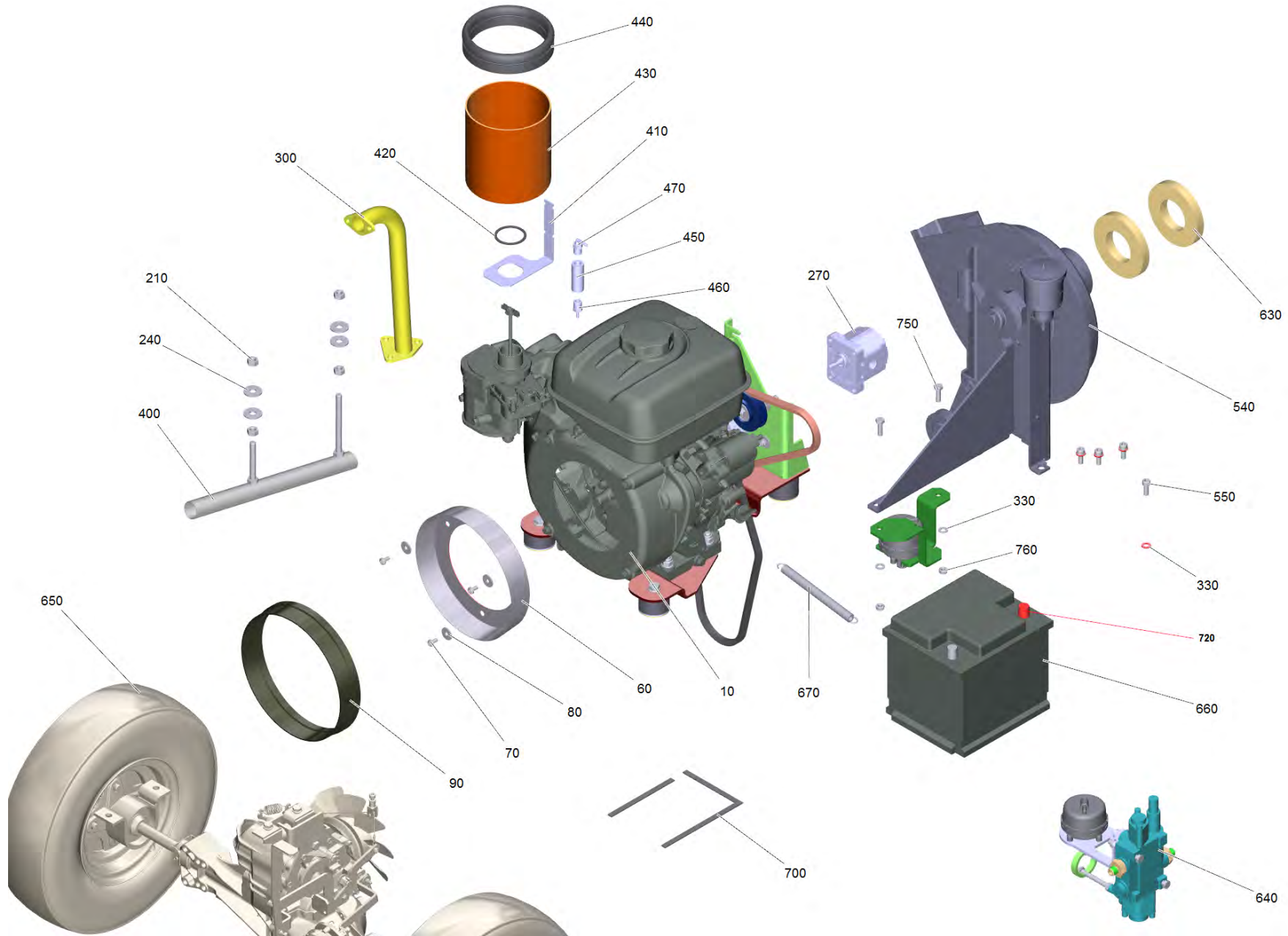

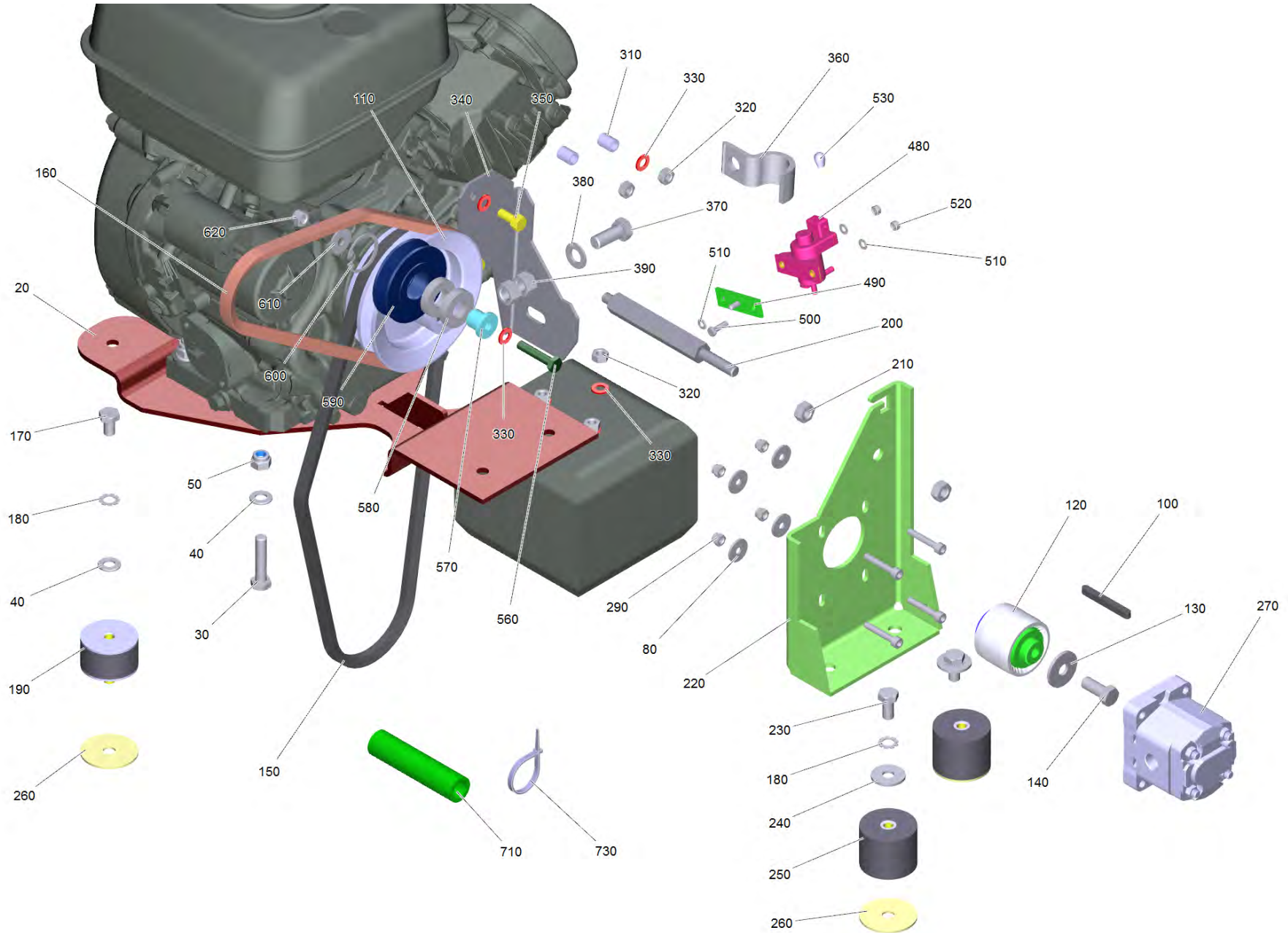

100 Antrieb Motor Benzin GX270

POS	Artikelnr.	Beschreibung	Anzahl	Einheit	Fußnotentext
10	6.491-973.0	Motor Honda GX 270	1.000	ST	
20	4.040-083.0	Blechteil Traeger Motor	1.000	ST	
30	7.304-426.0	6kt-Schraube M10x45-8.8-A3E ISO 4017	4.000	ST	
40	7.312-005.0	Scheibe 10-200HV-A3E ISO 7090	6.000	ST	
50	7.311-511.0	6kt-Mutter M10-8-A2E ISO 7040	4.000	ST	
60	5.032-347.0	Luftkanal	1.000	ST	
70	7.306-089.0	Schraube M6x12 -8.8-R2R (In6Rd)	3.000	ST	
80	7.312-260.0	Scheibe 6 -100HV-A3E ISO 7094	7.000	ST	
90	6.365-413.0	Dichtungsprofil	0.730	M	ALS METERWARE BESTELLEN
100	6.905-999.0	Passfeder	1.000	ST	
110	5.625-013.0	Riemenscheibe Benzin T3	1.000	ST	
120	6.463-000.0	Kupplung MOTOR-HY PUMPE	1.000	ST	
130	7.312-262.0	Scheibe 10 -100HV-A3E ISO 7094	1.000	ST	
140	6.304-073.0	6kt-Schr. 7/16-20UNF-8.8-A2E ISO 4017	1.000	ST	
150	6.348-008.0	Keilriemen XPA 982	1.000	ST	
160	6.348-410.0	Keilriemen XPA 757	1.000	ST	
170	7.304-410.0	6kt-Schraube M10x16-8.8-A3E ISO 4017	2.000	ST	
180	7.312-160.0	Zahnscheibe A10,5 -FSt-A3E DIN 6797	4.000	ST	
190	6.339-170.0	Gummipuffer	2.000	ST	
200	5.055-304.0	Strebe	1.000	ST	
210	7.311-006.0	6kt-Mutter M10 -8-A3E ISO 4032	6.000	ST	
220	5.057-473.0	Blechteil Rahmen Motorhalter	1.000	ST	
230	7.304-414.0	6kt-Schraube M10x20-8.8-A3E ISO 4017	2.000	ST	
240	7.312-285.0	Scheibe 10 -200HV-A2E ISO7093-1	6.000	ST	
250	6.339-127.0	Gummipuffer	2.000	ST	
260	5.116-060.0	Scheibe	4.000	ST	
270	6.503-082.0	Hydraulikpumpe	1.000	ST	
290	7.311-512.0	6kt-Mutter M 6-8-A2E ISO 7040	4.000	ST	
300	4.462-137.0	Kruemmer kpl. B	1.000	ST	
310	5.110-651.0	Huelse	2.000	ST	
320	7.311-004.0	6kt-Mutter M8 -8-A3E ISO 4032	5.000	ST	
330	7.312-004.0	Scheibe 8 -200HV-A3E ISO 7090	16.000	ST	
340	5.059-991.0	Blechteil	1.000	ST	

100 Antrieb Motor Benzin GX270

POS	Artikelnr.	Beschreibung	Anzahl	Einheit	Fußnotentext
350	6.304-033.0	Schraube 5/16-24UNF	2.000	ST	
360	7.373-030.0	Rohrschelle 28,5-ST-A2E DIN 1592	1.000	ST	
370	7.304-435.0	6kt-Schraube M12x30-8.8-A3E ISO 4017	1.000	ST	
380	7.312-008.0	Scheibe 12-200HV-A3E ISO 7090	1.000	ST	
390	7.311-008.0	6kt-Mutter M12-8-A3E ISO 4032	2.000	ST	
400	4.462-140.0	Auspuff	1.000	ST	
410	5.062-436.0	Blechteil Halter Abscheider	1.000	ST	
420	5.062-584.0	Distanzring	1.000	ST	
430	5.032-775.0	Luftkanal	1.000	ST	
440	6.365-498.0	Dichtungsprofil	0.600	M	ALS METERWARE BESTELLEN
450	5.123-252.0	Rohr Kraftstoff Abscheider	1.000	ST	
460	6.123-266.0	Schlauchnippel d4/R1/4"	1.000	ST	
470	6.123-267.0	Schlauchnippel 90° d4/R1/4"	1.000	ST	
480	6.472-970.0	Magnetventil Pneumatik	1.000	ST	
490	4.007-014.0	Blech kpl.	1.000	ST	
500	7.304-460.0	6kt-Schraube M 5x16-A4-70 ISO 4017	1.000	ST	
510	7.312-002.0	Scheibe 5-200HV-A3E ISO 7090	3.000	ST	
520	7.311-431.0	6kt-Mutter M 5-1.4305 ISO 10511	3.000	ST	
530	6.368-391.0	Schutzkappe	1.000	ST	
540		Geblaese Benzin T3	1.000	ST	
550	7.306-041.0	Zyl.Schr. M8x20 -8.8-A2E ISO 4762	4.000	ST	
560	7.304-404.0	6kt-Schraube M8x40-8.8-A2E ISO 4017	1.000	ST	
570	5.100-231.0	Buchse	1.000	ST	
580	7.401-022.0	Kugellager 16003-2RS-WST PREISW. DIN 625	2.000	ST	
590	5.100-409.0	Spannrolle XPA 72	1.000	ST	
600	7.343-017.0	Sicherungsring 35x1,5-FST-PHR DIN 472	1.000	ST	
610	7.312-277.0	Scheibe 8-200HV-A2E ISO7093-1	1.000	ST	
620	7.311-510.0	6kt-Mutter M 8-8-A2E ISO 7040	1.000	ST	
630	6.363-168.0	Dichtung	2.000	ST	
640	4.040-328.0	Steuerblock Antrieb KM 100/100	1.000	ST	
650	4.040-197.0	Antrieb Achse T3 KM100/100	1.000	ST	
660	7.654-001.0	Batterie 50Ah 12V	1.000	ST	
670	6.330-197.0	Zugfeder	1.000	ST	

100 Antrieb Motor Benzin GX270

POS	Artikelnr.	Beschreibung	Anzahl	Einheit	Fußnotentext
680	6.288-050.0	Motorenoel 1L	1.000	ST	
700	6.273-043.0	Dichtband Zellgummi 9x4	0.500	M	ALS METERWARE BESTELLEN
710	6.390-219.0	Schutzschlauch	0.550	M	ALS METERWARE BESTELLEN
720	6.642-147.0	Polabdeckung "+"	1.000	ST	
730	6.641-464.0	Kabelbinder	2.000	ST	
740	7.303-046.0	Schraube M6x12 -St-R3R (In6Rd)	5.000	ST	
750	7.304-399.0	6kt-Schraube M 8x25-8.8-A2E ISO 4017	2.000	ST	
760	7.311-427.0	6kt-Mutter M8 -04-A2E ISO 10511	2.000	ST	

400 Auspuff (4.462-140.0)

POS	Artikelnr.	Beschreibung	Anzahl	Einheit
2	7.304-062.0	6kt-Schraube M10x70-A2-70 ISO 4017	1.000	ST
3	7.304-053.0	6kt-Schraube M10x110 -A2-70 ISO 4017	1.000	ST

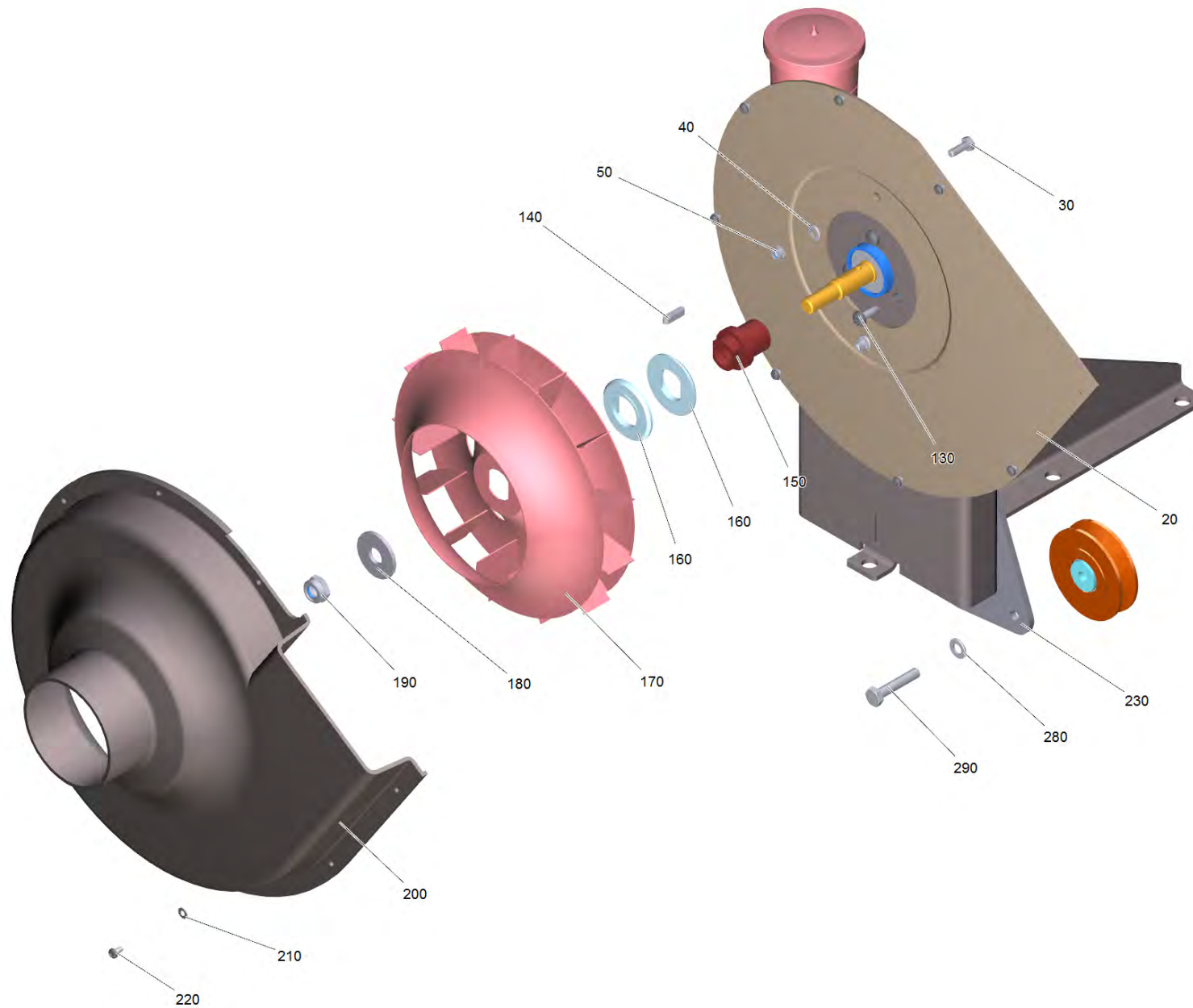

540 Geblaese Benzin T3

POS	Artikelnr.	Beschreibung	Anzahl	Einheit	Fußnotentext
20	5.059-806.0	Blechteil	1.000	ST	
30	7.304-521.0	6kt-Schraube M 6x16-A4-70 ISO 4017	2.000	ST	
40	7.312-003.0	Scheibe 6 -200HV-A3E ISO 7090	2.000	ST	
50	7.311-425.0	6kt-Mutter M6 -04-A2E ISO 10511	2.000	ST	
60	5.122-189.0	Flansch Guss	1.000	ST	
70	7.401-105.0	Kugellager 6003-2RS Wälzl.St DIN 625	2.000	ST	
80	5.110-913.0	Buchse	1.000	ST	
90	5.100-413.0	Welle Geblaese	1.000	ST	
100	7.318-079.0	Passfeder A 5x5x25-C45R DIN 6885	1.000	ST	
110	5.625-492.0	Keilriemenscheibe	1.000	ST	
120	7.343-006.0	Sicherungsring 17x1-St-ph DIN 471	1.000	ST	
130	7.303-047.0	Schraube M6x16 -St-R3R (In6Rd)	3.000	ST	
140	7.318-070.0	Passfeder 5x5x20-C45R DIN 6885-1	1.000	ST	
150	5.112-651.0	Buchse Antrieb Geblaese	1.000	ST	
160	6.312-046.0	Distanzscheibe	2.000	ST	
170	6.484-326.0	Geblaeserad D=222mm	1.000	ST	
180	7.312-287.0	Scheibe 12-200HV-A2E ISO7093-1	1.000	ST	
190	7.311-429.0	6kt-Mutter M12-04-A2E ISO 10511	1.000	ST	
200	6.961-164.0	Gehaeuse	1.000	ST	
210	7.312-001.0	Scheibe 4 -200HV-A3E ISO 7089	8.000	ST	
220	7.303-030.0	Schraube M4x8 -St-P2R (In6Rd)	8.000	ST	
230	5.059-721.0	Blechteil	1.000	ST	
240	5.100-231.0	Buchse	1.000	ST	
250	7.401-022.0	Kugellager 16003-2RS-WST PREISW. DIN 625	2.000	ST	
260	5.100-409.0	Spannrolle XPA 72	1.000	ST	
270	7.343-017.0	Sicherungsring 35x1,5-FST-PHR DIN 472	1.000	ST	
280	7.312-004.0	Scheibe 8 -200HV-A3E ISO 7090	2.000	ST	
290	7.304-404.0	6kt-Schraube M8x40-8.8-A2E ISO 4017	1.000	ST	
300	7.312-277.0	Scheibe 8-200HV-A2E ISO7093-1	1.000	ST	
310	7.311-510.0	6kt-Mutter M 8-8-A2E ISO 7040	2.000	ST	
320	5.112-019.0	Buchse Riemenspanner	1.000	ST	
330	7.304-399.0	6kt-Schraube M 8x25-8.8-A2E ISO 4017	1.000	ST	
340	5.409-368.0	Nippel	1.000	ST	

540 Gebläse Benzin T3

POS	Artikelnr.	Beschreibung	Anzahl	Einheit	Fußnotentext
350	6.362-168.0	O-Ring 22,3 X 2,4-NBR 70	1.000	ST	
360	5.070-048.0	Behälter	1.000	ST	
370	5.030-389.0	Formteil	1.000	ST	
380	5.063-471.0	Deckel	1.000	ST	
390	6.362-858.0	O-Ring 11,0 X 1,5	1.000	ST	
400	7.343-031.0	Sicherungsring 14x1-FST-PHR DIN 471	1.000	ST	
410	6.389-093.0	Schlauch Niederdruck D 7.5 mm	0.700	M	ALS METERWARE BESTELLEN
420	6.388-537.0	Schlauchselle	2.000	ST	
430	6.641-403.0	Durchführungsstelle	1.000	ST	

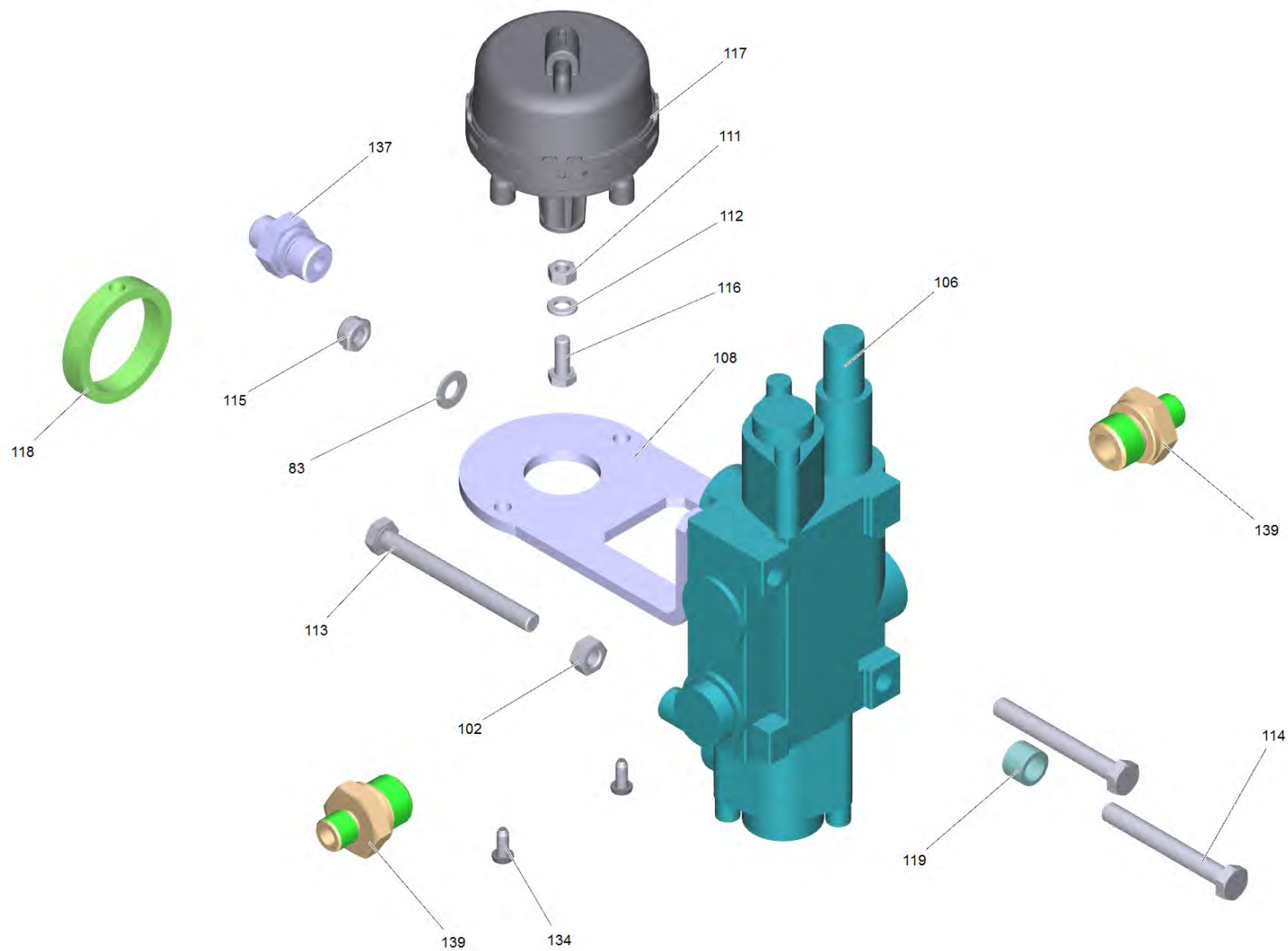

640 Steuerblock Antrieb KM 100/100 (4.040-328.0)

POS	Artikelnr.	Beschreibung	Anzahl	Einheit
83	7.312-004.0	Scheibe 8 -200HV-A3E ISO 7090	2.000	ST
102	7.311-004.0	6kt-Mutter M8 -8-A3E ISO 4032	1.000	ST
106	6.413-249.0	Ventil mit Druckbegrenzung	1.000	ST
111	7.311-003.0	6kt-Mutter M6 -8-A2E ISO 4032	1.000	ST
112	7.312-003.0	Scheibe 6 -200HV-A3E ISO 7090	1.000	ST
113	7.304-098.0	6kt-Schraube M8x80-8.8-A2E ISO 4014	1.000	ST
114	7.304-402.0	6kt-Schraube M8x65-8.8-A2E ISO 4017	2.000	ST
115	7.311-427.0	6kt-Mutter M8 -04-A2E ISO 10511	2.000	ST
116	7.304-521.0	6kt-Schraube M 6x16-A4-70 ISO 4017	1.000	ST
117	6.421-332.0	Unterdruckdose rund Hub 25 mm	1.000	ST
118	5.114-501.0	Ring	1.000	ST
119	5.110-749.0	Huelse	1.000	ST
134	7.303-097.0	Schraube 5x12 -10.9-R2R (K-In6Rd)	2.000	ST
137	6.386-667.0	Verschraubung	1.000	ST
139	6.386-712.0	Verschraubung	2.000	ST

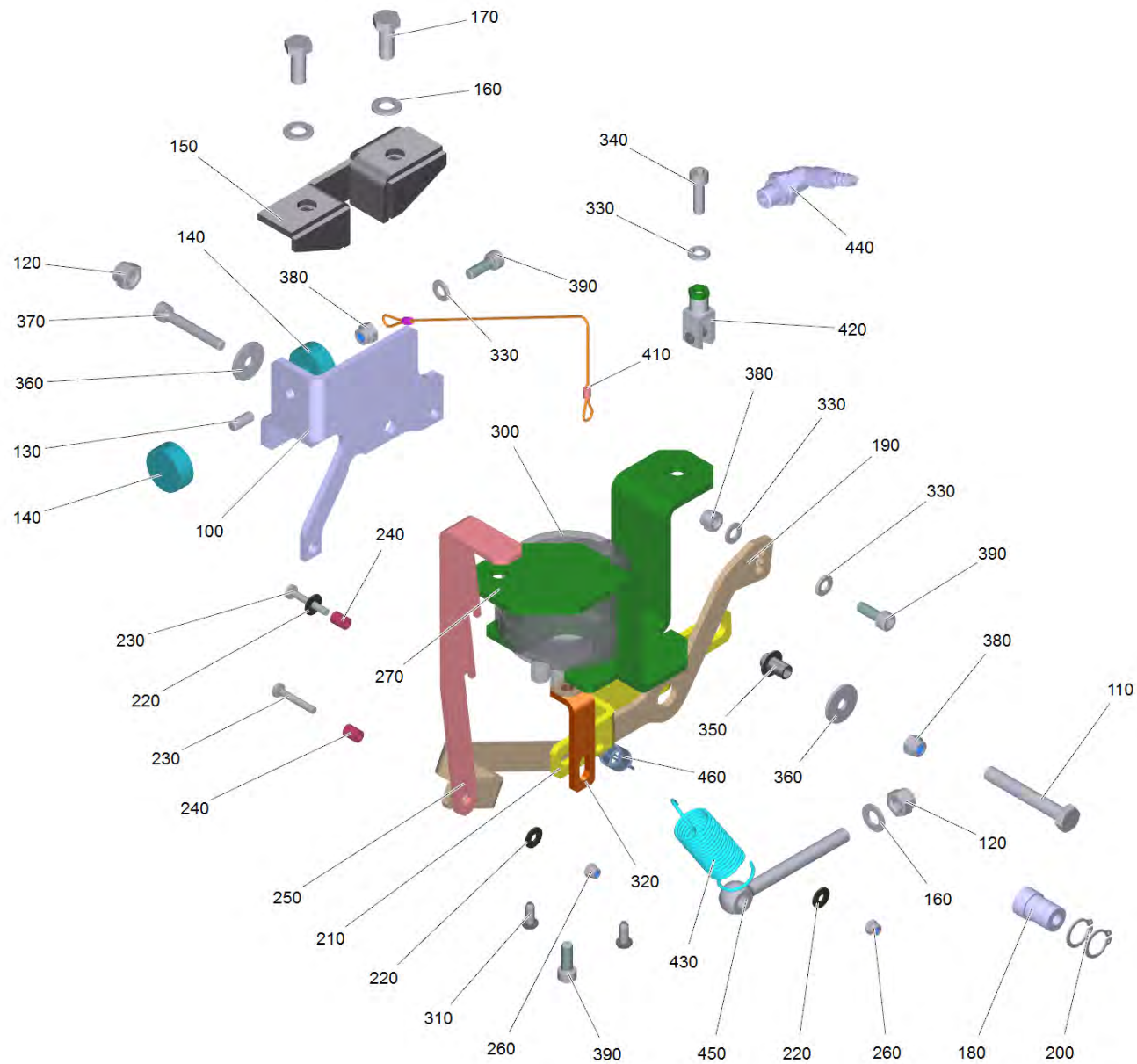

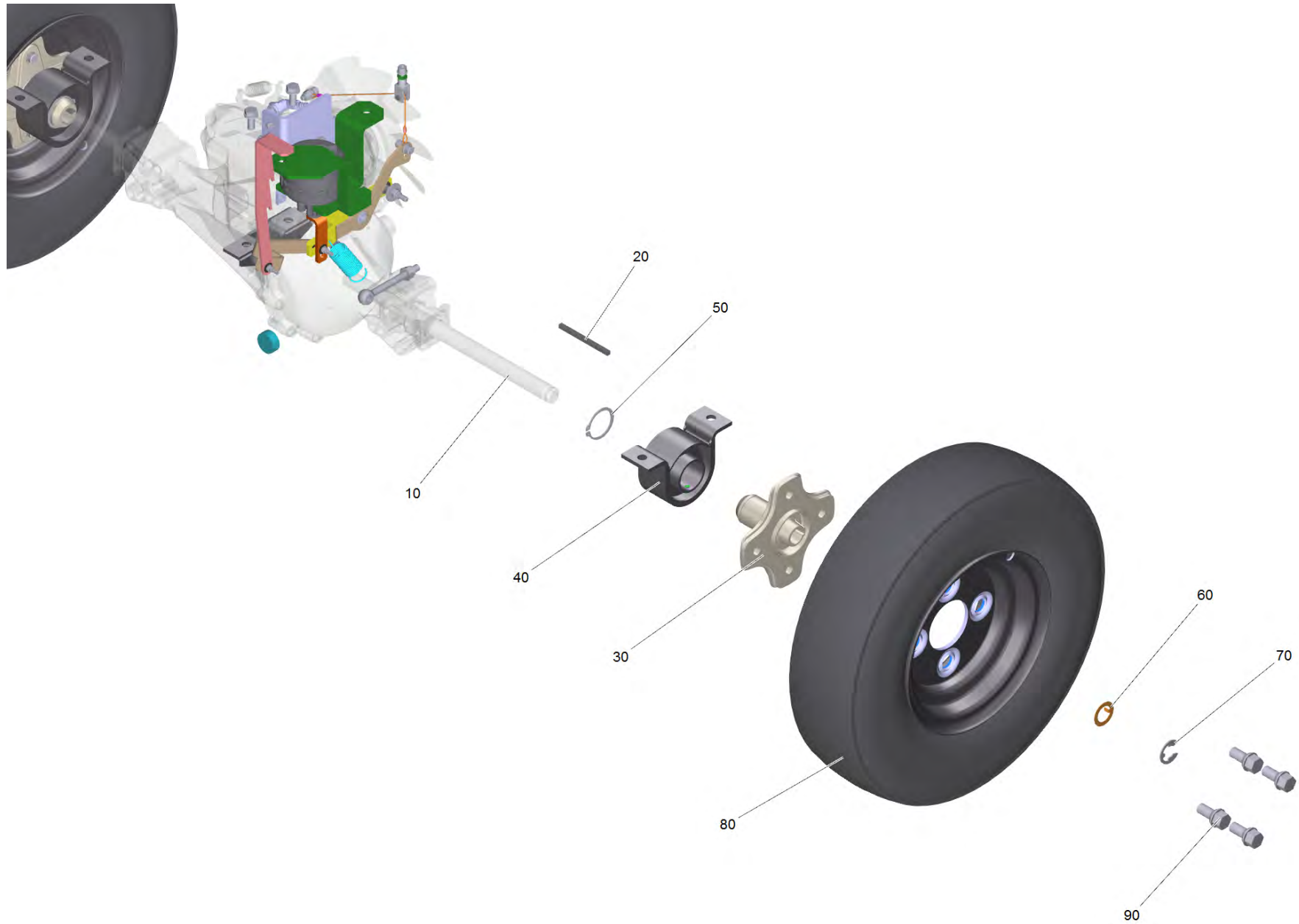

650 Antrieb Achse T3 KM100/100 (4.040-197.0)

POS	Artikelnr.	Beschreibung	Anzahl	Einheit
10	6.454-143.0	Getriebe Achse T3	1.000	ST
20	6.491-741.0	Passfeder	2.000	ST
30	5.122-007.0	Flansch Rad	2.000	ST
40	6.401-355.0	Flanschlager	2.000	ST
50	7.343-011.0	Sicherungsring 35x1,5-FST-VZ DIN 471	2.000	ST
60	5.061-912.0	Blechteil Sicherung Achse	2.000	ST
70	7.343-304.0	Sicherungsscheibe 15 -A2 DIN 6799	2.000	ST
80	6.435-833.0	Rad kpl.	2.000	ST
90	6.997-362.0	Radschraube G12x21-10.9	8.000	ST
100	4.040-205.0	Drehmomentstuetze Achse	1.000	ST
110	7.304-031.0	6kt-Schraube M8x55-8.8-A2E ISO 4014	1.000	ST
120	7.311-510.0	6kt-Mutter M 8-8-A2E ISO 7040	1.000	ST
130	7.307-027.0	Gewindebolzen M6x14-B 8.8-A2E DIN 976	1.000	ST
140	6.339-242.0	Gummipuffer 80 Shore	2.000	ST
150	4.040-206.0	Gegenhalter Drehmomentstuetze	1.000	ST
160	7.312-004.0	Scheibe 8 -200HV-A3E ISO 7090	4.000	ST
170	7.304-397.0	6kt-Schraube M8x20-8.8-A2E ISO 4017	2.000	ST
180	5.110-015.0	Huelse Bypass T3	1.000	ST
190	5.062-773.0	Hebel Bypass T3	1.000	ST
200	7.343-031.0	Sicherungsring 14x1-FST-PHR DIN 471	2.000	ST
210	5.062-774.0	Wippe Bremse T3	1.000	ST
220	7.312-281.0	Scheibe 4 -200HV-A2E ISO7093-1	2.000	ST
230	7.306-211.0	Schraube M 4x25-A2-70 (IN6RD)	1.000	ST
240	5.115-981.0	Huelse	1.000	ST
250	5.062-657.0	Griff Freilauf T3	1.000	ST
260	7.311-424.0	6kt-Mutter M4 -8-A2E ISO 7040	1.000	ST
270	5.062-776.0	Halter Unterdruckdose T3	1.000	ST
290	7.311-427.0	6kt-Mutter M8 -04-A2E ISO 10511	2.000	ST
300	6.421-332.0	Unterdruckdose rund Hub 25 mm	1.000	ST
310	7.303-097.0	Schraube 5x12 -10.9-R2R (K-In6Rd)	2.000	ST
320	5.062-775.0	Hebel Bremse Hub T3	1.000	ST
330	7.312-003.0	Scheibe 6 -200HV-A3E ISO 7090	4.000	ST
340	7.306-022.0	Zyl.Schr. M 6x20-8.8-A2E ISO4762	1.000	ST

650 Antrieb Achse T3 KM100/100 (4.040-197.0)

POS	Artikelnr.	Beschreibung	Anzahl	Einheit
350	5.110-644.0	Huelse	1.000	ST
360	7.312-260.0	Scheibe 6 -100HV-A3E ISO 7094	2.000	ST
370	7.306-029.0	Zyl.Schr. M 6x40-8.8-A2E DIN 912	1.000	ST
380	7.311-512.0	6kt-Mutter M 6-8-A2E ISO 7040	3.000	ST
390	7.306-020.0	Zyl.Schr. M 6x16-8.8-A2E DIN 912	2.000	ST
410	6.431-083.0	Seilzug Bypass T3	1.000	ST
420	6.437-377.0	Gabelkopf M6	1.000	ST
430	6.330-255.0	Zugfeder	1.000	ST
440	6.454-154.0	Schlauchnippel einstellbar 7/16" 90°	1.000	ST
450	6.373-700.0	Augenschraube LAM8x80-4.6-A3E DIN 444	1.000	ST
460	6.330-473.0	Zugfeder	1.000	ST

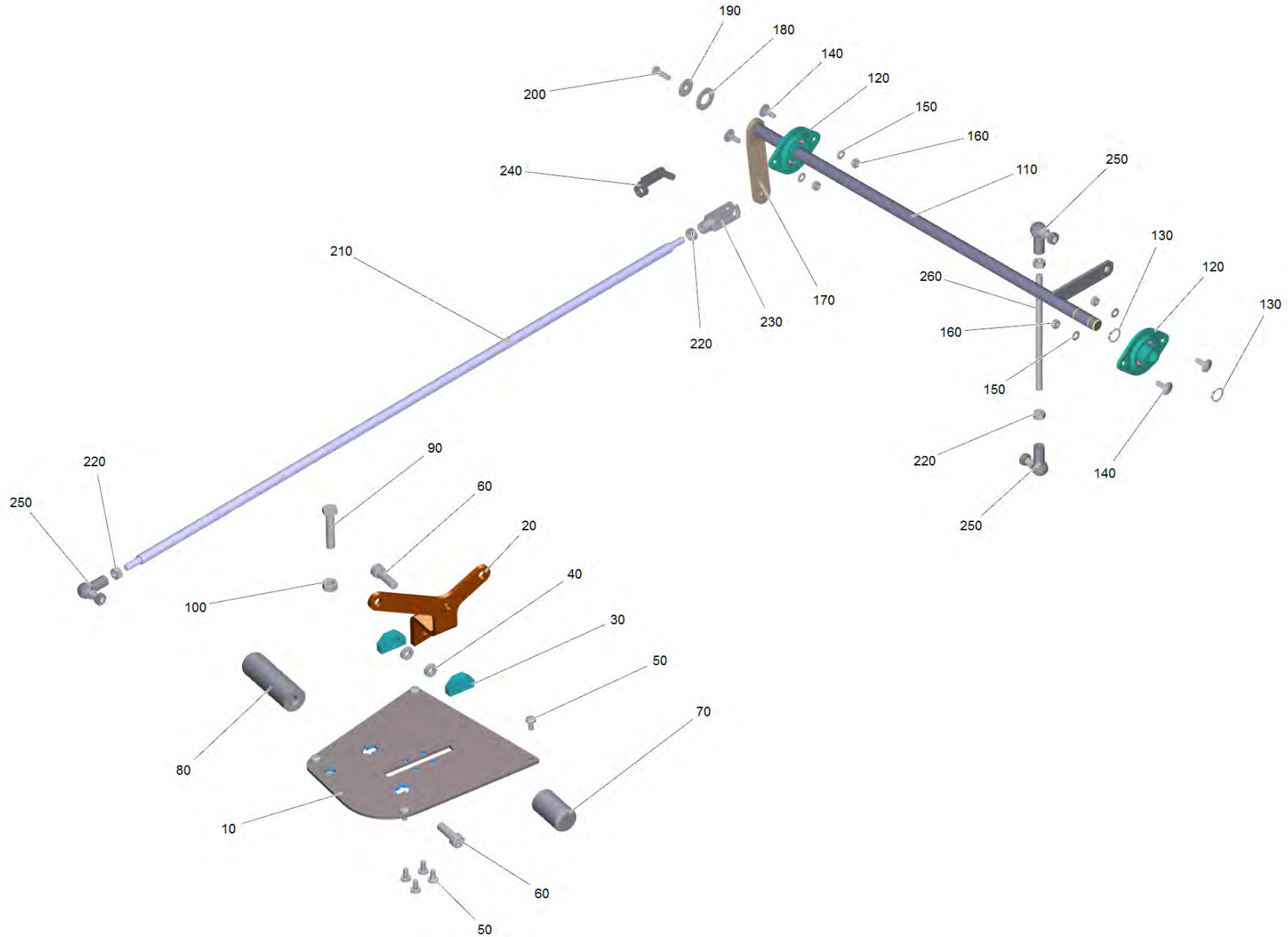

110 Steuerung Pedal Verbrenner

POS	Artikelnr.	Beschreibung	Anzahl	Einheit
10	4.002-131.0	Grundplatte kpl.	1.000	ST
20	4.481-267.0	Hebel kpl.	1.000	ST
30	5.251-047.0	Lagerbock	2.000	ST
40	7.401-174.0	Kugellager 688-2Z -Wälzl.St DIN 625	2.000	ST
50	7.306-089.0	Schraube M6x12 -8.8-R2R (In6Rd)	8.000	ST
60	7.306-063.0	Zyl.Schr. M10x30-8.8-A3E ISO4762	2.000	ST
70	5.321-701.0	Griff	1.000	ST
80	5.321-702.0	Griff	1.000	ST
90	7.304-514.0	6kt-Schraube M10x50-A2-70 ISO 4017	1.000	ST
100	7.311-006.0	6kt-Mutter M10 -8-A3E ISO 4032	1.000	ST
110	4.100-199.0	Welle kpl.	1.000	ST
120	6.401-242.0	Flanschlager	2.000	ST
130	7.343-004.0	Sicherungsring 15x1-FST-PHR DIN 471	2.000	ST
140	7.303-139.0	Fl.Rd.Schr. M6x20 -A2 DIN 603	4.000	ST
150	7.312-003.0	Scheibe 6 -200HV-A3E ISO 7090	4.000	ST
160	7.311-512.0	6kt-Mutter M 6-8-A2E ISO 7040	4.000	ST
170	5.004-947.0	Lasche	1.000	ST
180	7.312-028.0	Scheibe 14-200HV-A3E ISO7090	1.000	ST
190	7.312-260.0	Scheibe 6 -100HV-A3E ISO 7094	1.000	ST
200	7.304-536.0	6kt-Schraube M 6x20-A4-70 ISO 4017	1.000	ST
210	5.107-236.0	Stange	1.000	ST
220	7.311-004.0	6kt-Mutter M8 -8-A3E ISO 4032	4.000	ST
230	7.462-013.0	Gabelkopf G8x32 -St-A2E DIN71752	1.000	ST
240	6.316-054.0	Bolzen	1.000	ST
250	7.462-023.0	Winkelgelenk CS13 -A2E DIN 71802	3.000	ST
260	5.010-265.0	Gewindebolzen Verstellung B 60 W	1.000	ST

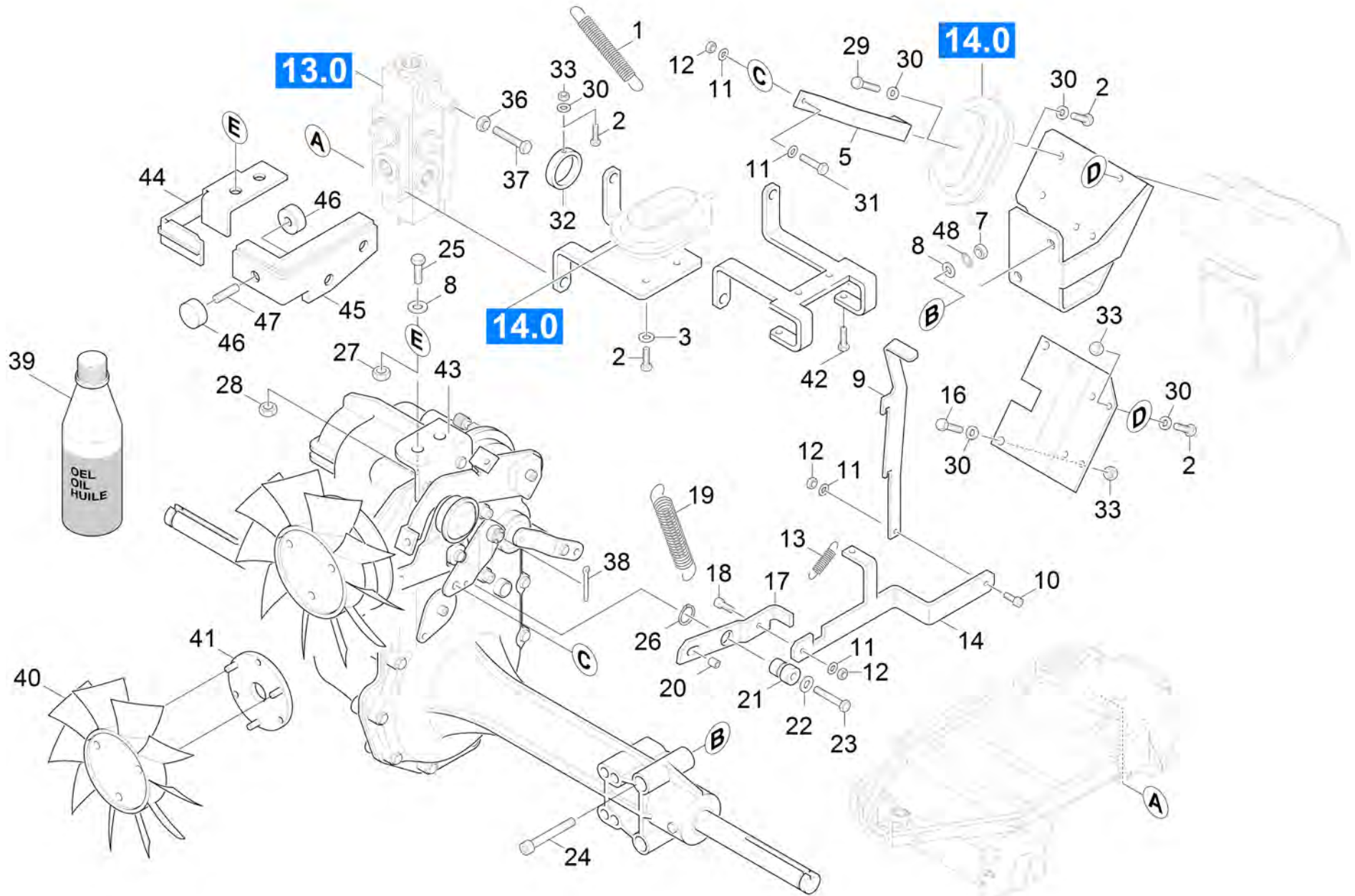

120 Anbauteile Achse

POS	Artikelnr.	Beschreibung	Anzahl	Einheit	Fußnotentext
1	6.330-197.0	Zugfeder	1.000	ST	
2	7.306-182.0	Flachkopfschraube M5x16 -A2-70 ISO 14583	5.000	ST	
5	5.059-839.0	Blechteil (SP)	1.000	ST	
7	7.311-427.0	6kt-Mutter M8 -04-A2E ISO 10511	1.000	ST	
8	7.312-004.0	Scheibe 8 -200HV-A3E ISO 7090	3.000	ST	
9	5.059-847.0	Blechteil (SP)	1.000	ST	
10	7.304-363.0	6kt-Schr. M 4X 20- 8.8-A2E ISO 4017	1.000	ST	
11	7.312-281.0	Scheibe 4 -200HV-A2E ISO7093-1	3.000	ST	
12	7.311-424.0	6kt-Mutter M4 -8-A2E ISO 7040	1.000	ST	
13	6.330-056.0	Zugfeder	1.000	ST	
14	5.059-835.0	Blechteil	1.000	ST	
16	7.306-158.0	Zyl.Schr. M 5x20-A4-70 ISO 4762	2.000	ST	
17	5.059-844.0	Blechteil Bypass Bremse	1.000	ST	
18	7.305-251.0	Senkschraube M 4x16-4.8-A2R ISO 7046-1	1.000	ST	
19	6.330-198.0	Zugfeder	1.000	ST	
20	5.115-981.0	Huelse	1.000	ST	
21	5.115-980.0	Huelse	1.000	ST	
24	7.304-402.0	6kt-Schraube M8x65-8.8-A2E ISO 4017	1.000	ST	
25	7.304-397.0	6kt-Schraube M8x20-8.8-A2E ISO 4017	3.000	ST	
26	7.343-031.0	Sicherungsring 14x1-FST-PHR DIN 471	1.000	ST	
27	7.311-004.0	6kt-Mutter M8 -8-A3E ISO 4032	9.000	ST	
28	7.311-006.0	6kt-Mutter M10 -8-A3E ISO 4032	6.000	ST	
29	7.306-071.0	Schraube M5x10 -8.8-R2R (In6Rd)	1.000	ST	
30	7.312-002.0	Scheibe 5-200HV-A3E ISO 7090	12.000	ST	
31	7.306-211.0	Schraube M 4x25-A2-70 (IN6RD)	1.000	ST	
32	5.114-501.0	Ring	1.000	ST	
33	7.311-002.0	6kt-Mutter M5 -8-A2E ISO 4032	10.000	ST	
37	7.304-098.0	6kt-Schraube M8x80-8.8-A2E ISO 4014	1.000	ST	
38	7.316-344.0	Splint 2,5x28-St-A2E ISO 1234	1.000	ST	
39	4.070-489.0	Universal Oel SAE 20W50	2.000	ST	
40	6.484-335.0	Luefterrad kpl.	1.000	ST	POS.41 1x MITBESTELLEN
41	4.040-878.0	Scheibe Distanz kpl.	1.000	ST	
42	7.306-079.0	Schraube M5x25 -8.8-R2R (In6Rd)	2.000	ST	

120 Anbauteile Achse

POS	Artikelnr.	Beschreibung	Anzahl	Einheit	Fußnotentext
43	5.017-848.0	Winkel	1.000	ST	
44	4.040-562.0	Halter	1.000	ST	
45	5.062-153.0	Blechteil Winkel	1.000	ST	
46	6.339-242.0	Gummipuffer 80 Shore	2.000	ST	
47	7.307-027.0	Gewindebolzen M6x14-B 8.8-A2E DIN 976	1.000	ST	
48	7.312-160.0	Zahnscheibe A10,5 -FSt-A3E DIN 6797	4.000	ST	

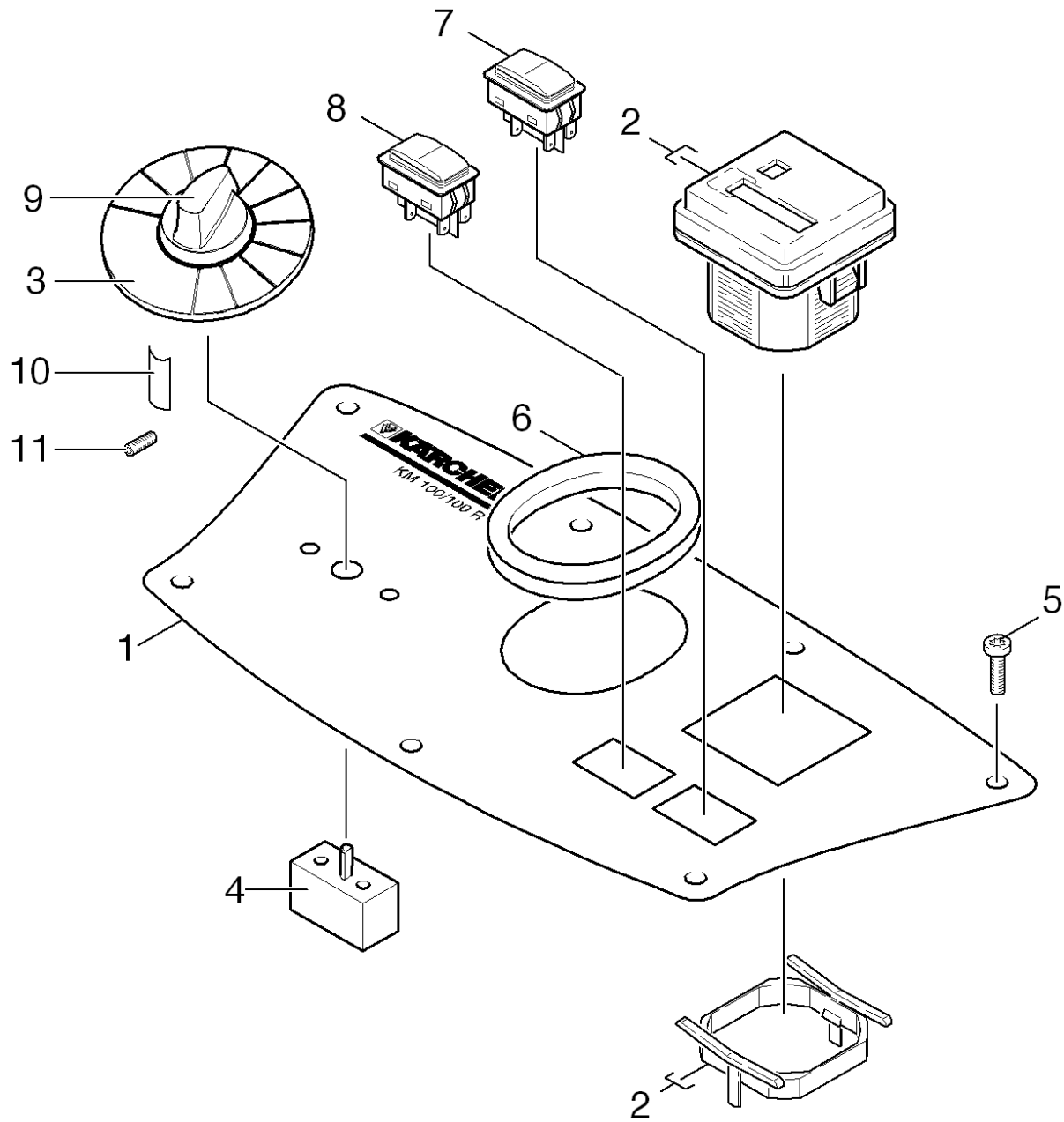

130 Konsole

POS	Artikelnr.	Beschreibung	Anzahl	Einheit
1	5.008-559.0	Blech Konsole	1.000	ST
2	6.681-081.0	Betriebsstundenzaehler	1.000	ST
3	5.032-738.0	Formteil Symbolscheibe KM100/100R	1.000	ST
4	6.635-481.0	Schalter Bedienkonzept	1.000	ST
5	6.303-125.0	Schraube 5x20-Sonder In6Rd+Spitze	7.000	ST
6	6.368-106.0	Kantenschutz	1.000	M
7	6.632-478.0	Taster Filterreinigung	1.000	ST
8	6.632-475.0	Taster 2-polig Hupe	1.000	ST
9	5.321-738.0	Griff Bedienkonzept	1.000	ST
10	6.313-014.0	Federungselement	1.000	ST
11	7.307-025.0	Gewindestift M3x10 St-45H ISO 4029	1.000	ST

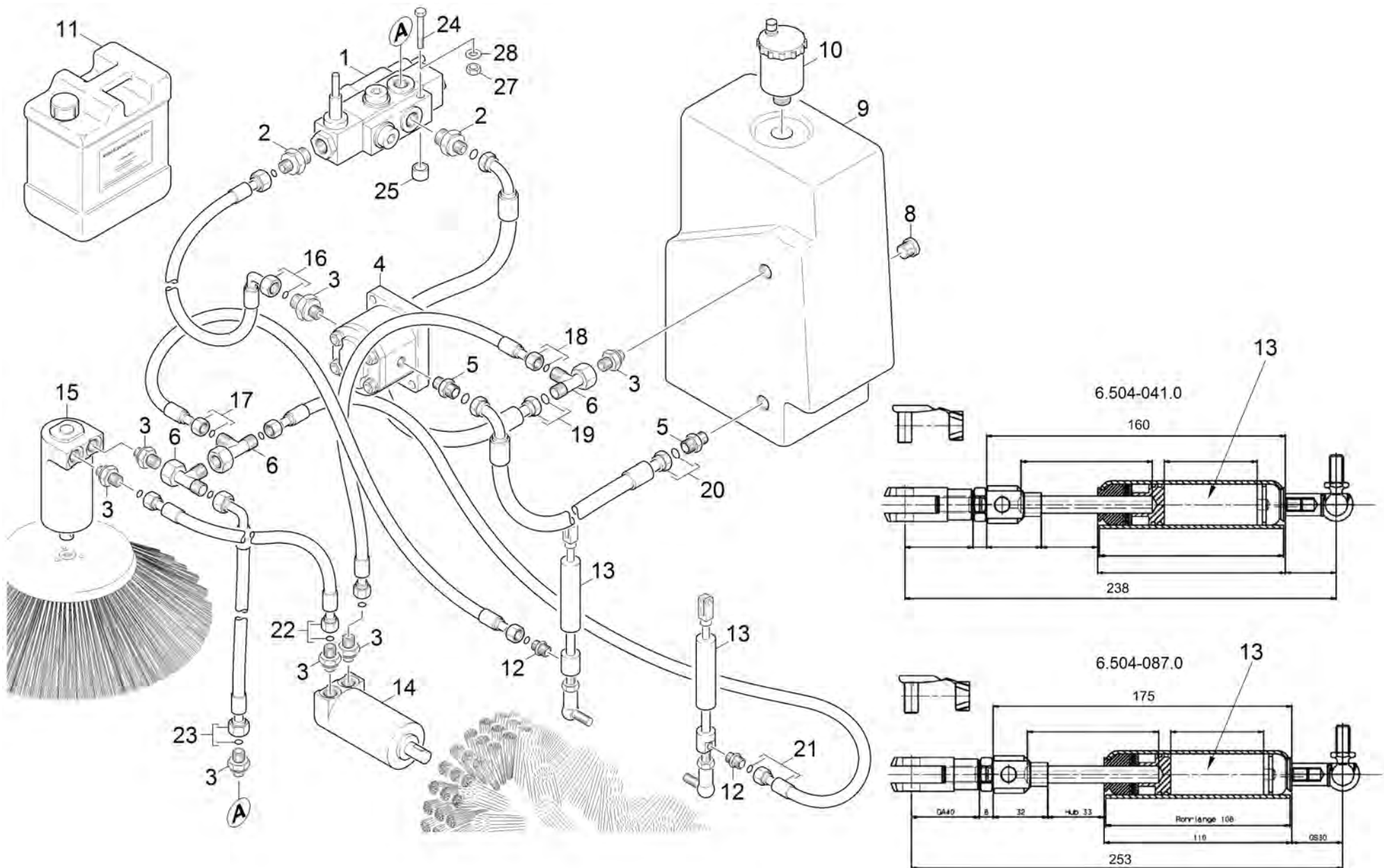

140 Hydraulik

POS	Artikelnr.	Beschreibung	Anzahl	Einheit	Werknummer ab	Werknummer bis	Bemerkung
1	6.413-249.0	Ventil mit Druckbegrenzung	1.000	ST			
2	6.386-712.0	Verschraubung	2.000	ST			
3	6.386-667.0	Verschraubung	7.000	ST			
4	6.503-082.0	Hydraulikpumpe	1.000	ST	11408		
4	6.474-042.0	Hydraulikpumpe	1.000	ST		11407	
5	6.386-634.0	Verschraubung	2.000	ST			
6	6.386-636.0	Verschraubung	3.000	ST			
8	6.997-539.0	Verschlusschraube (VSTIR38ED)	1.000	ST			
9	5.071-134.0	Tank Hydraulik	1.000	ST			
10	6.369-722.0	Entluefter	1.000	ST			
11	4.070-306.0	Hydraulikoel 1,5 L	6.000	ST			
12	6.392-184.0	Einschraubverschraubung G 1/8"	2.000	ST			
13	6.504-087.0	Hydraulikzylinder mit Gasdruckfeder	2.000	ST			L=253mm
13	6.504-041.0	HYDRAULIKZYLINDER	2.000	ST			L=238mm
14	6.503-017.0	Hydraulikmotor Kehrwalze	1.000	ST			
15	6.503-018.0	Hydraulikmotor	1.000	ST			
16	6.390-738.0	Hydraulikschlauch	1.000	ST			
17	6.390-826.0	Hydraulikschlauch	1.000	ST			
18	6.390-742.0	Hydraulikschlauch	1.000	ST			
19	6.390-739.0	Hydraulikschlauch	1.000	ST			
20	6.390-737.0	Hydraulikschlauch	1.000	ST			
21	6.390-827.0	Hydraulikschlauch	1.000	ST			
22	6.390-741.0	Hydraulikschlauch	1.000	ST			
23	6.390-740.0	Hydraulikschlauch	1.000	ST			
24	7.304-402.0	6kt-Schraube M8x65-8.8-A2E ISO 4017	4.000	ST			
25	5.110-749.0	Huelse	1.000	ST			
27	7.311-427.0	6kt-Mutter M8 -04-A2E ISO 10511	4.000	ST			
28	7.312-004.0	Scheibe 8 -200HV-A3E ISO 7090	4.000	ST			

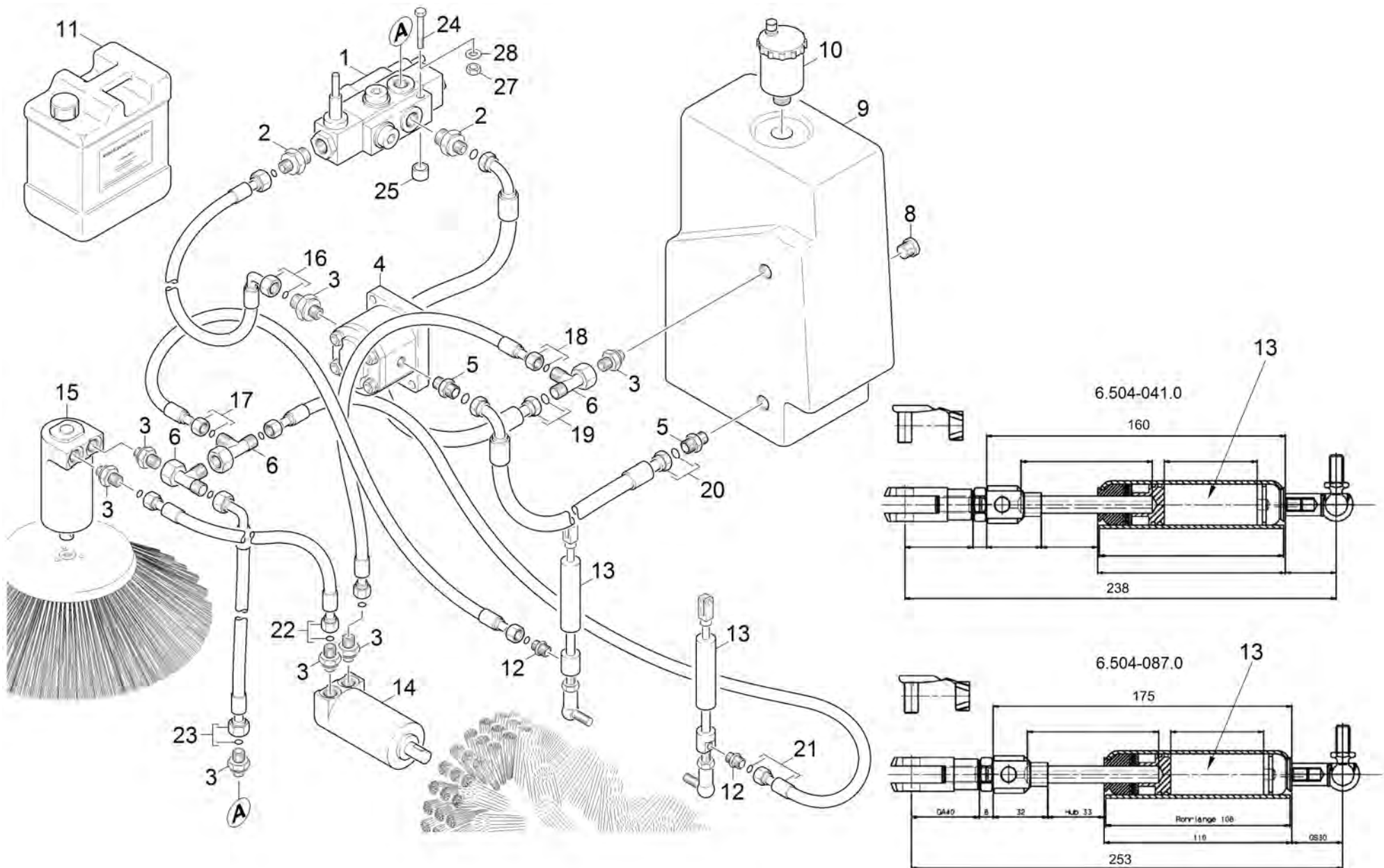

150 Hydraulik

POS	Artikelnr.	Beschreibung	Anzahl	Einheit	Werknummer ab	Werknummer bis
1	6.413-249.0	Ventil mit Druckbegrenzung	1.000	ST		
2	6.386-712.0	Verschraubung	2.000	ST		
3	6.386-667.0	Verschraubung	7.000	ST		
4	6.503-082.0	Hydraulikpumpe	1.000	ST	10551	
4	6.474-042.0	Hydraulikpumpe	1.000	ST		10550
5	6.386-634.0	Verschraubung	2.000	ST		
6	6.386-636.0	Verschraubung	3.000	ST		
8	6.997-539.0	Verschlussschraube (VSTIR38ED)	1.000	ST		
9	5.071-134.0	Tank Hydraulik	1.000	ST		
10	6.369-722.0	Entluefter	1.000	ST		
11	4.070-306.0	Hydraulikoel 1,5 L	6.000	ST		
12	6.392-184.0	Einschraubverschraubung G 1/8"	2.000	ST		
13	6.504-087.0	Hydraulikzylinder mit Gasdruckfeder	2.000	ST	11356	
13	6.504-041.0	HYDRAULIKZYLINDER	2.000	ST		11355
14	6.503-017.0	Hydraulikmotor Kehrwalze	1.000	ST		
15	6.503-018.0	Hydraulikmotor	1.000	ST		
16	6.390-738.0	Hydraulikschlauch	1.000	ST		
17	6.390-826.0	Hydraulikschlauch	1.000	ST		
18	6.390-742.0	Hydraulikschlauch	1.000	ST		
19	6.390-739.0	Hydraulikschlauch	1.000	ST		
20	6.390-737.0	Hydraulikschlauch	1.000	ST		
21	6.390-827.0	Hydraulikschlauch	1.000	ST		
22	6.390-741.0	Hydraulikschlauch	1.000	ST		
23	6.390-740.0	Hydraulikschlauch	1.000	ST		
24	7.304-402.0	6kt-Schraube M8x65-8.8-A2E ISO 4017	4.000	ST		
25	5.110-749.0	Huelse	1.000	ST		
27	7.311-427.0	6kt-Mutter M8 -04-A2E ISO 10511	4.000	ST		
28	7.312-004.0	Scheibe 8 -200HV-A3E ISO 7090	4.000	ST		

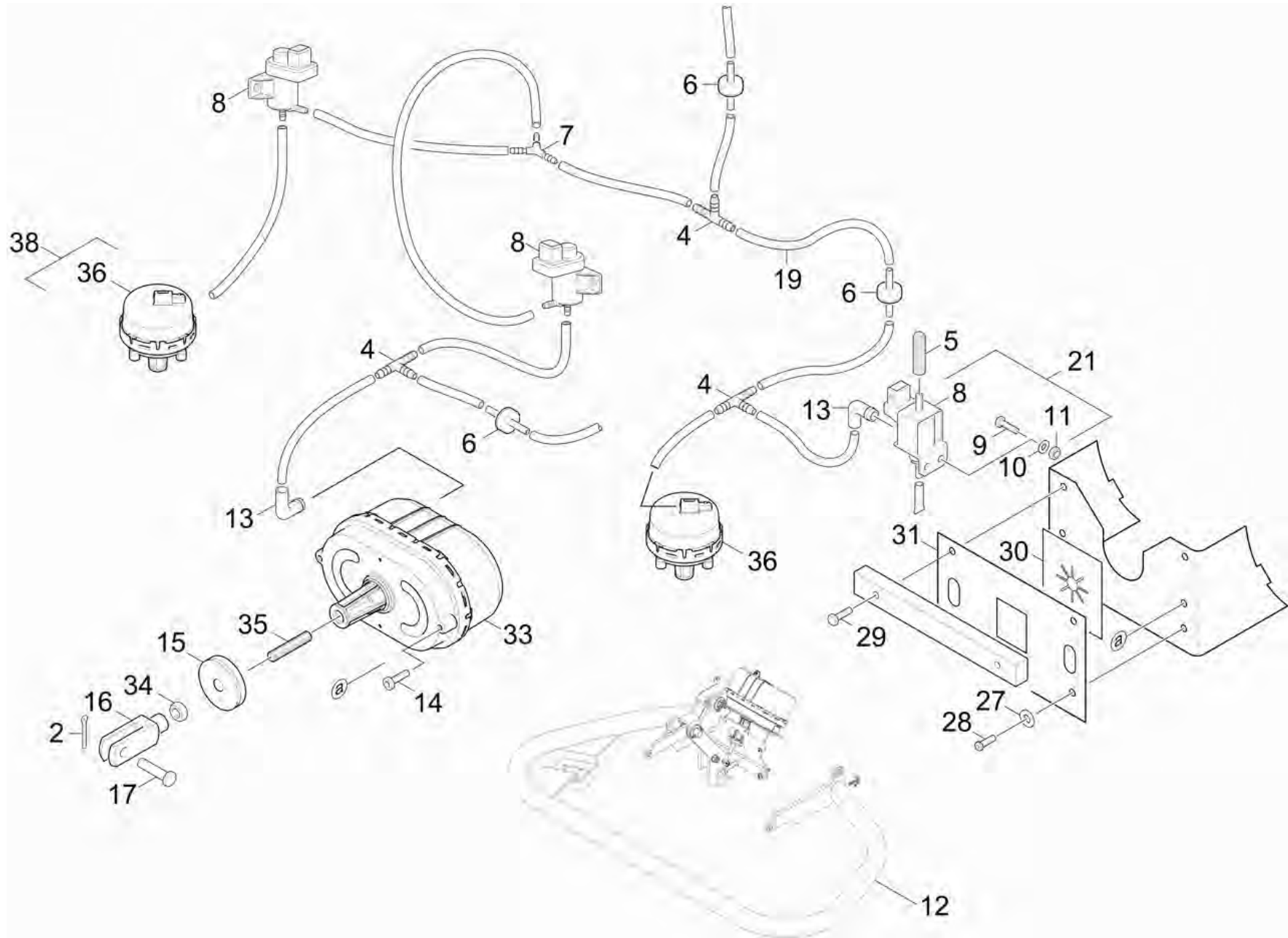

160 Pneumatik

POS	Artikelnr.	Beschreibung	Anzahl	Einheit	Werknummer ab	Werknummer bis	Fußnotentext
2	7.316-333.0	Splint 2x20-St-A2E ISO 1234	2.000	ST			
4	6.388-904.0	T-Schlauchtuelle	3.000	ST			
5	6.761-000.0	Filter	1.000	ST			
6	6.413-592.0	Rueckschlagventil	3.000	ST			
7	6.389-359.0	Y-Tuelle Y4	1.000	ST			
8	6.472-970.0	Magnetventil Pneumatik	1.000	ST			
9	7.304-521.0	6kt-Schraube M 6x16-A4-70 ISO 4017	2.000	ST			
10	7.312-003.0	Scheibe 6 -200HV-A3E ISO 7090	2.000	ST			
11	7.311-425.0	6kt-Mutter M6 -04-A2E ISO 10511	2.000	ST			
12	2.641-693.0	UBS Anhebung Seitenbesen B/D/LPG	1.000	ST			
13	6.386-873.0	Winkelstueck 90°	2.000	ST			
14	7.306-094.0	Schraube M6x25 -8.8-R3R (In6Rd)	2.000	ST			
14	7.303-107.0	Schraube 5x16 -10.9-P2R (K- In6Rd)	2.000	ST			
15	4.040-815.0	Staubschutz Unterdruckdose oval	1.000	ST			
16	7.462-013.0	Gabelkopf G8x32 -St-A2E DIN71752	1.000	ST			
17	5.316-343.0	Bolzen	1.000	ST			
19	6.389-794.0	Schlauch PU 6/4	1.000	M			ALS METERWARE BESTELLEN
21	2.884-269.0	ET-Satz Magnetventil	1.000	ST		10313	
22	4.007-014.0	Blech kpl.	1.000	ST	10313		
23	7.306-182.0	Flachkopfschraube M5x16 -A2-70 ISO 14583	1.000	ST	10313		
24	7.311-431.0	6kt-Mutter M 5-1.4305 ISO 10511	3.000	ST	10313		
25	7.312-002.0	Scheibe 5-200HV-A3E ISO 7090	3.000	ST	10313		
27	7.312-267.0	Scheibe 5-A2 ISO 7094	2.000	ST			
28	7.303-037.0	Schraube M5x10 -St-P2R (In6Rd)	2.000	ST			

160 Pneumatik

POS	Artikelnr.	Beschreibung	Anzahl	Einheit	Werknummer ab	Werknummer bis	Fußnotentext
29	7.306-158.0	Zyl.Schr. M 5x20-A4-70 ISO 4762	2.000	ST			
30	5.365-259.0	Gummilippe	1.000	ST			
31	5.008-325.0	Blech	1.000	ST			
33	6.421-331.0	Unterdruckdose oval Hub 45 mm	1.000	ST			
34	7.311-224.0	6kt-Mutter M 8-04-A2E ISO 4035	1.000	ST			
35	5.309-127.0	Gewindestange M8	1.000	ST			
36	6.421-332.0	Unterdruckdose rund Hub 25 mm	1.000	ST			
38	2.641-699.0	UBS Unterdruckdose Antrieb KM 100/100 B/	1.000	ST			

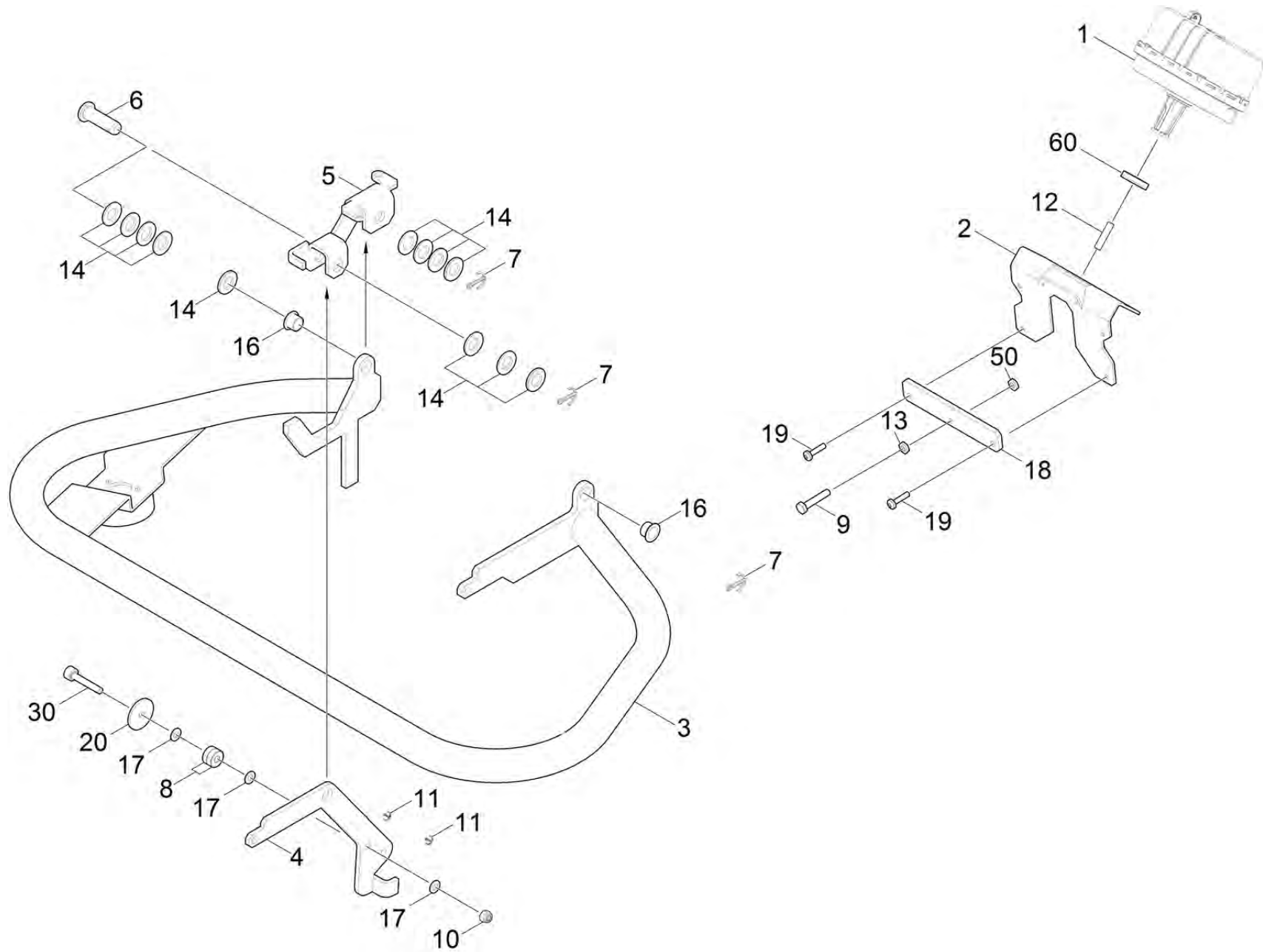

12 UBS Anhebung Seitenbesen B/D/LPG (2.641-693.0)

POS	Artikelnr.	Beschreibung	Anzahl	Einheit
1	6.421-331.0	Unterdruckdose oval Hub 45 mm	1.000	ST
2	5.061-904.0	Blechteil Halter Unterdruckdose	1.000	ST
3	4.040-757.0	Rohr Buegel kpl.	1.000	ST
4	4.040-786.0	Hebel kpl.	1.000	ST
5	5.061-890.0	Blechteil Halter rechts	1.000	ST
6	7.316-020.0	Bolzen B-16x50 -St-A2E ISO 2341	1.000	ST
7	7.316-352.0	Splint 4x36 -St-A2E ISO 1234	3.000	ST
8	7.401-149.0	Kugellager 608-2RS -Wälzl.St DIN 625	2.000	ST
9	7.306-075.0	Zyl.Schr. M 8x 40-8.8-A2E ISO 4762	1.000	ST
10	7.311-510.0	6kt-Mutter M 8-8-A2E ISO 7040	1.000	ST
11	7.316-333.0	Splint 2x20-St-A2E ISO 1234	2.000	ST
12	5.309-127.0	Gewindestange M8	1.000	ST
13	7.311-224.0	6kt-Mutter M 8-04-A2E ISO 4035	1.000	ST
14	7.312-019.0	Scheibe 16-200HV-A3E ISO7090	12.000	ST
16	6.437-484.0	Lagerbuchse	2.000	ST
17	7.312-017.0	Scheibe 8-A2 ISO 7089	3.000	ST
18	5.094-400.0	Blechteil Verstellung	1.000	ST
19	7.306-071.0	Schraube M5x10 -8.8-R2R (In6Rd)	2.000	ST
20	5.094-399.0	Blechteil Scheibe	1.000	ST
30	7.306-094.0	Schraube M6x25 -8.8-R3R (In6Rd)	2.000	ST
40	7.304-407.0	6kt-Schraube M 8x45-8.8-A2E ISO 4017	1.000	ST
50	7.311-224.0	6kt-Mutter M 8-04-A2E ISO 4035	1.000	ST
60	4.040-815.0	Staubschutz Unterdruckdose oval	1.000	ST

60 Staubschutz Unterdruckdose oval (4.040-815.0)

POS	Artikelnr.	Beschreibung	Anzahl	Einheit
1	5.062-199.0	Scheibe D 34	1.000	ST

15 Staubschutz Unterdruckdose oval (4.040-815.0)

POS	Artikelnr.	Beschreibung	Anzahl	Einheit
1	5.062-199.0	Scheibe D 34	1.000	ST

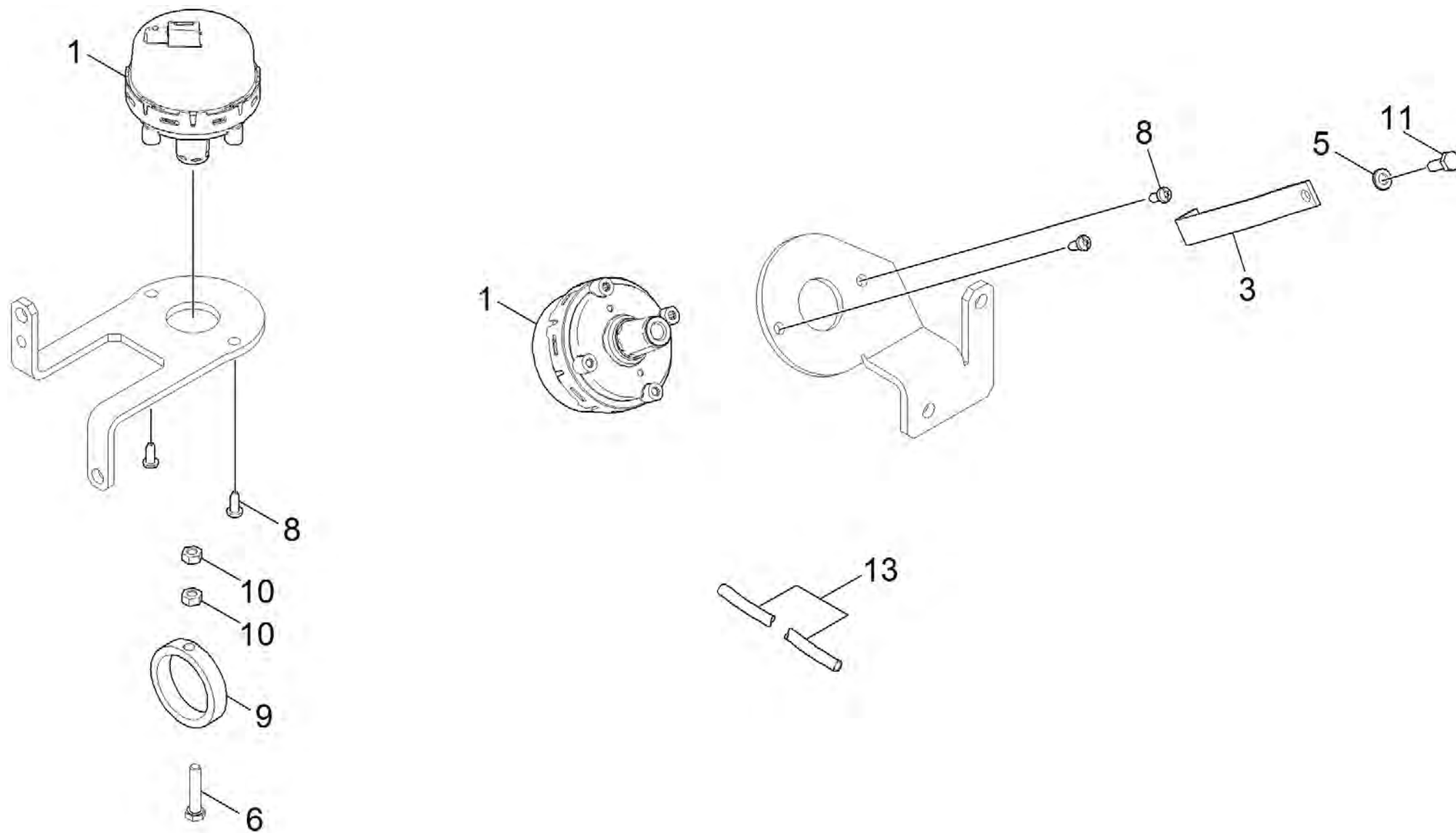

38 UBS Unterdruckdose Antrieb KM 100/100 B/ (2.641-699.0)

POS	Artikelnr.	Beschreibung	Anzahl	Einheit
1	6.421-332.0	Unterdruckdose rund Hub 25 mm	2.000	ST
3	5.061-852.0	Blechteil Hebel Bremse	1.000	ST
5	7.312-003.0	Scheibe 6 -200HV-A3E ISO 7090	1.000	ST
6	7.304-387.0	6kt-Schraube M 6x30-8.8-A2E ISO 4017	1.000	ST
8	7.303-097.0	Schraube 5x12 -10.9-R2R (K-In6Rd)	4.000	ST
9	5.114-501.0	Ring	1.000	ST
10	7.311-003.0	6kt-Mutter M6 -8-A2E ISO 4032	2.000	ST
11	7.304-521.0	6kt-Schraube M 6x16-A4-70 ISO 4017	1.000	ST
13	6.389-794.0	Schlauch PU 6/4	1.000	M

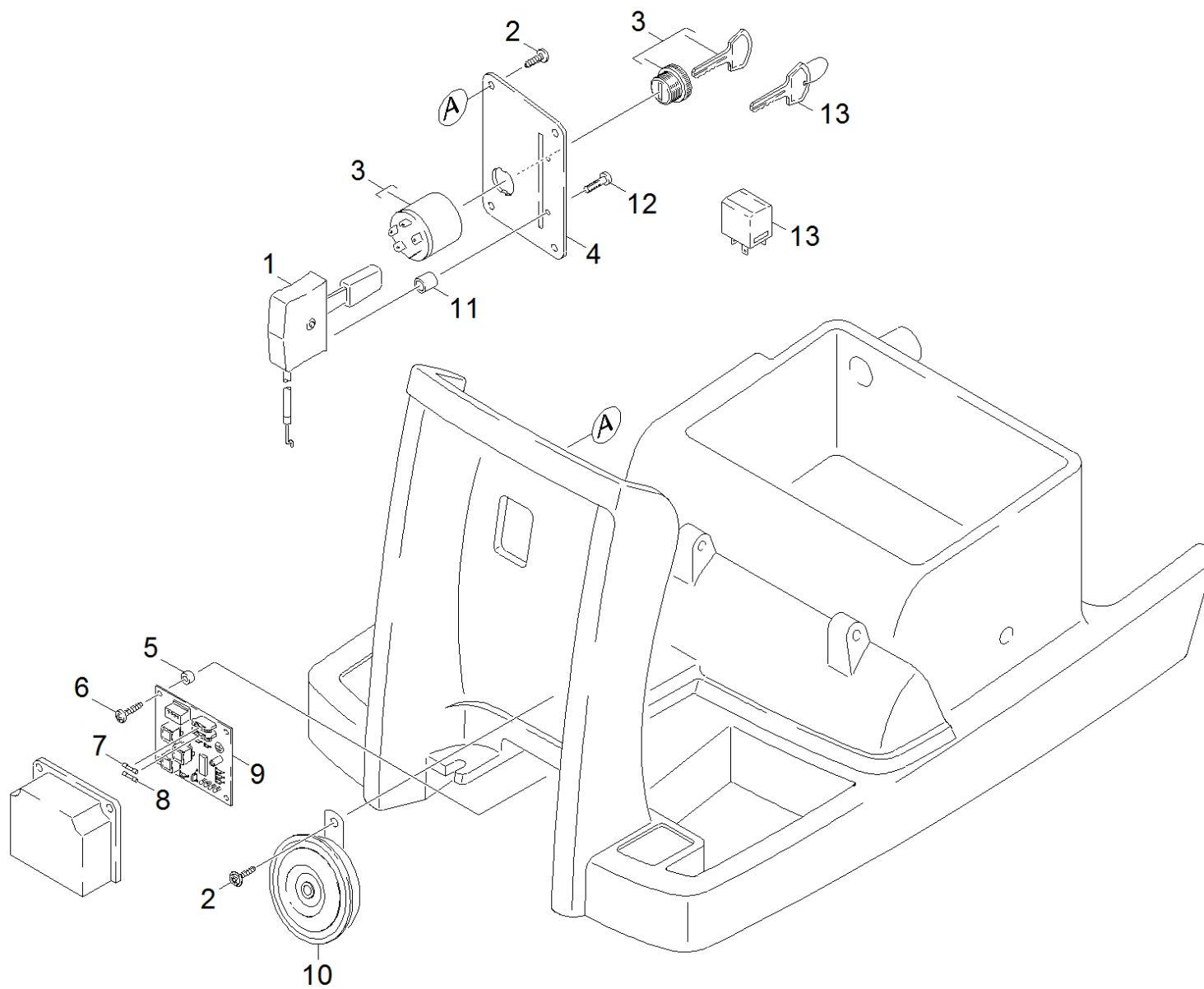

170 E-Ausruestung

POS	Artikelnr.	Beschreibung	Anzahl	Einheit
1	6.491-736.0	Choke	1.000	ST
2	6.303-125.0	Schraube 5x20-Sonder In6Rd+Spitze	4.000	ST
3	6.375-212.0	Schluesselschalter	1.000	ST
4	5.056-164.0	Blechteil	2.000	ST
5	6.312-008.0	Scheibe	8.000	ST
6	6.303-245.0	Zyl.Schr. 3X18-ST-A2E	4.000	ST
7	7.644-007.0	Sicherungseinsatz C 7,5 DIN 72581-3	1.000	ST
8	7.644-017.0	Sicherungseinsatz C10 DIN 72581-3	1.000	ST
9	6.682-378.0	Steuerplatine 12 V/NE	1.000	ST
10	6.635-326.0	Signalhorn	1.000	ST
11	5.110-552.0	Buchse	2.000	ST
13	6.375-335.0	Schluesel fuer Ersatz	1.000	ST
14	6.633-632.0	Doppelrelais 12V 2x10A	1.000	ST

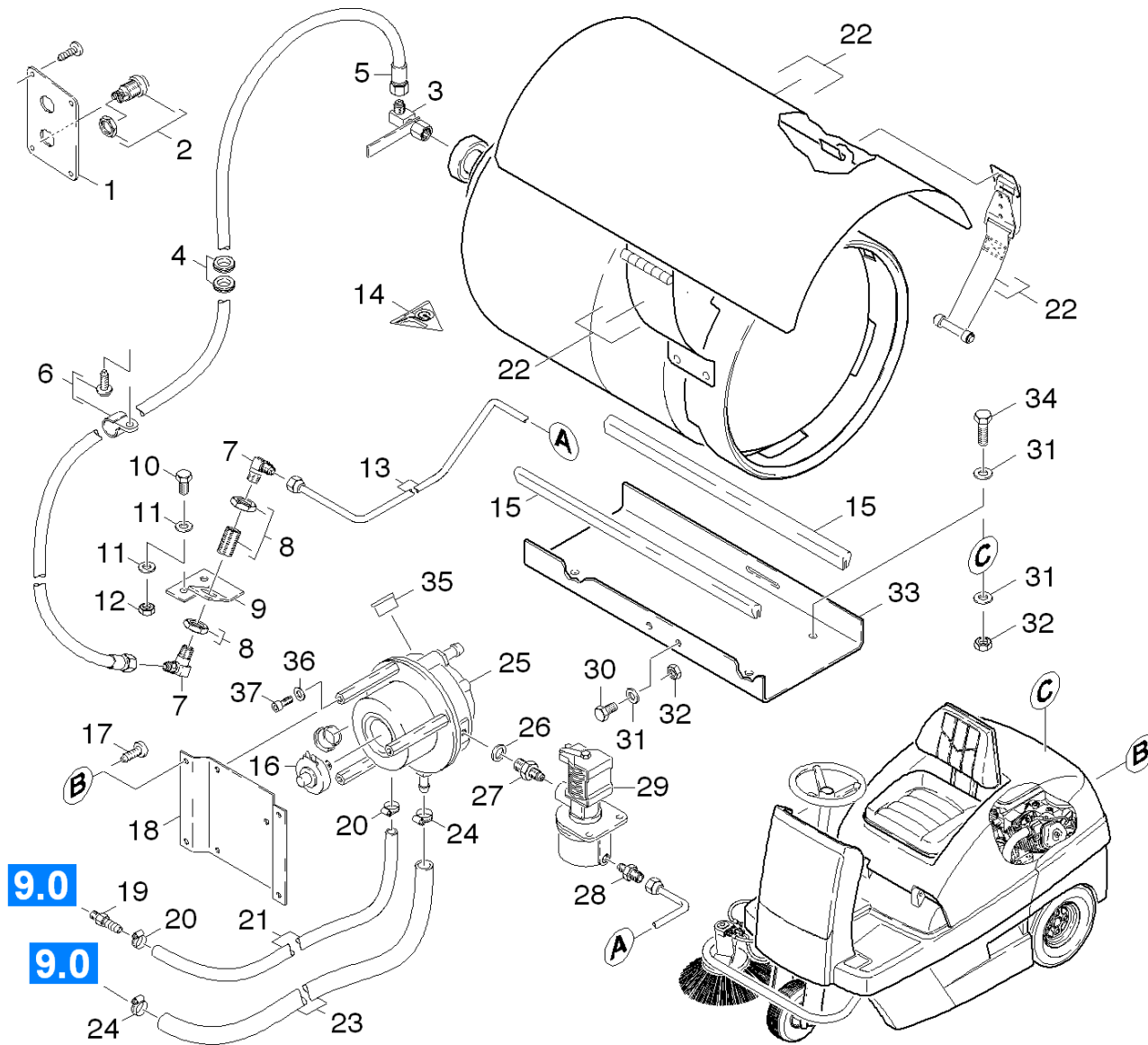

180 Gas

POS	Artikelnr.	Beschreibung	Anzahl	Einheit	Fußnotentext
1	5.007-840.0	Blech Konsole (SP)	1.000	ST	
2	6.631-950.0	Schalter	1.000	ST	
3	6.395-035.0	Anschluss Gasflasche	1.000	ST	
4	6.641-641.0	Durchfuehrungstuelle D32	2.000	ST	
5	6.390-987.0	HD-Schlauch	1.000	ST	
6	6.373-212.0	Rohrschelle	2.000	ST	
7	6.385-805.0	Winkelstueck	2.000	ST	
8	6.368-301.0	Schottverschraubung	1.000	ST	
9	5.058-622.0	Blechteil Halter Schottverschraubung (SP)	1.000	ST	
10	7.304-399.0	6kt-Schraube M 8x25-8.8-A2E ISO 4017	2.000	ST	
11	7.312-017.0	Scheibe 8-A2 ISO 7089	4.000	ST	
12	7.311-514.0	6kt-Mutter M 8-A2-70 ISO 7040	2.000	ST	
13	4.025-782.0	Rohr kpl. Gas	1.000	ST	
14	6.376-487.0	Schild	1.000	ST	
15	6.365-374.0	Dichtungsprofil	2.000	M	
16	6.491-624.0	Choke L237	1.000	ST	
17	6.303-125.0	Schraube 5x20-Sonder In6Rd+Spitze	3.000	ST	
18	5.058-613.0	Blechteil	1.000	ST	
19	6.390-276.0	Schlauchnippel	1.000	ST	
20	7.373-019.0	Schlauchschelle A 10-16x9-W4 DIN3017	2.000	ST	
21	6.391-058.0	Schlauch 5.5x10.5	1.000	ST	ALS METERWARE BESTELLEN
22	4.040-023.0	Deckel Set Lpg	1.000	ST	
23	6.390-291.0	Schlauch 9,0x14	1.000	ST	ALS METERWARE BESTELLEN
24	6.388-522.0	Schlauchschelle	2.000	ST	
25	6.635-363.0	Druckregler	1.000	ST	
26	6.421-213.0	Dichtring ID12 AD18 AL J22	1.000	ST	
27	6.395-034.0	Reduziernippel	1.000	ST	
28	6.395-033.0	Reduziernippel	1.000	ST	
29	6.686-116.0	Magnetventil LPG Absperrventil	1.000	ST	
30	7.304-415.0	6kt-Schraube M10x25-8.8-A3E ISO 4017	2.000	ST	
31	7.312-005.0	Scheibe 10-200HV-A3E ISO 7090	10.000	ST	
32	7.311-511.0	6kt-Mutter M10-8-A2E ISO 7040	6.000	ST	
33	5.023-650.0	Blechteil (SP)	1.000	ST	

180 Gas

POS	Artikelnr.	Beschreibung	Anzahl	Einheit	Fußnotentext
34	7.304-417.0	6kt-Schraube M10x30-8.8-A3E ISO 4017	4.000	ST	
35	6.368-064.0	Verschlussstopfen	2.000	ST	
36	7.312-003.0	Scheibe 6 -200HV-A3E ISO 7090	3.000	ST	
37	7.306-040.0	Zyl.Schr. M8x16 -8.8-A2E ISO4762	3.000	ST	
38	5.023-650.0	Blechteil (SP)	1.000	ST	

22 Deckel Set Lpg (4.040-023.0)

POS	Artikelnr.	Beschreibung	Anzahl	Einheit	Fußnotentext
1	4.040-016.0	Deckel komplett Lpg	1.000	ST	
2	5.062-456.0	Blechteil Halter Deckel	1.000	ST	
3	5.062-454.0	Blechteil Verschluss	1.000	ST	
4	5.501-022.0	Scharnier	2.000	ST	
5	6.375-002.0	Spannverschluss LPG	1.000	ST	
6	6.365-374.0	Dichtungsprofil	0.290	M	ALS METERWARE BESTELLEN
7	6.365-374.0	Dichtungsprofil	0.290	M	ALS METERWARE BESTELLEN
8	7.305-646.0	Senkschraube M 5x16-A2-70 DIN 7991	3.000	ST	
9	7.312-052.0	Scheibe 5 -A2 ISO 7089	3.000	ST	
10	7.311-431.0	6kt-Mutter M 5-1.4305 ISO 10511	3.000	ST	
11	7.305-053.0	Senkschraube M6x16-A2-70 (IN6RD)	6.000	ST	
12	7.312-045.0	Scheibe 6-200HV-P4E ISO 7089	8.000	ST	
13	7.311-425.0	6kt-Mutter M6 -04-A2E ISO 10511	8.000	ST	
14	7.306-030.0	Schraube M 6x14-A2-70 DIN 7984	2.000	ST	
15	6.437-666.0	Seil mit Schlaufen	1.000	ST	
16	7.316-470.0	Klappstecker 8x42-St-A2E DIN 11023	1.000	ST	
17	5.237-015.0	Aufkleber Sicherheitsverschluss LPG	1.000	ST	

29 Magnetventil LPG Absperrventil (6.686-116.0)

POS	Artikelnr.	Beschreibung	Anzahl	Einheit
10	6.686-612.0	Ersatzteil Absperrventil Magnetventil	1.000	ST

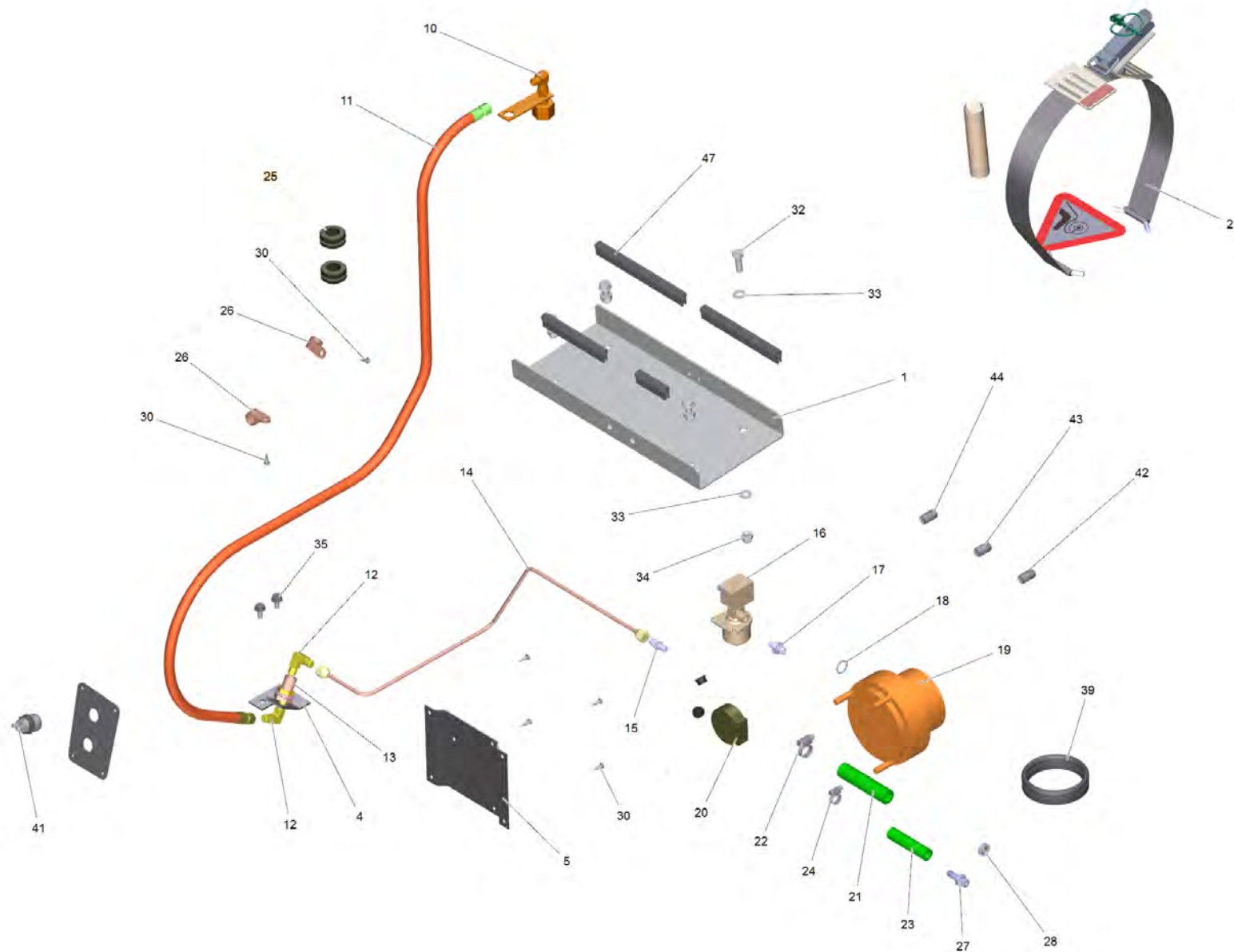

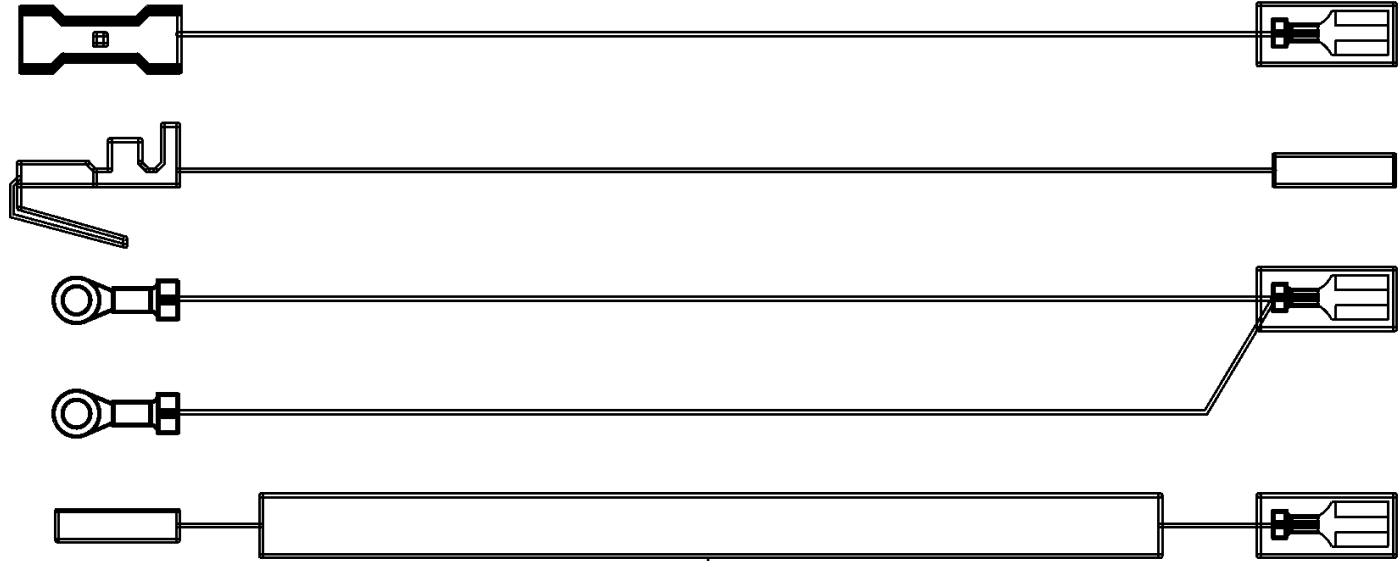

45

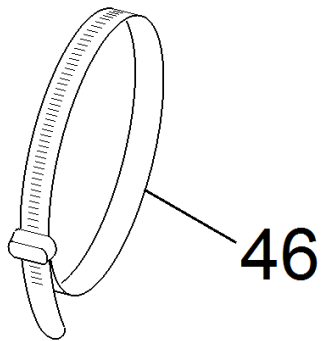

46

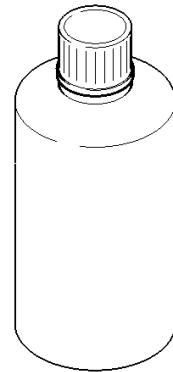

53

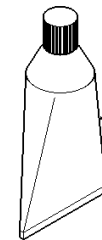

54

190 UBS KM 100/100 R LPG

POS	Artikelnr.	Beschreibung	Anzahl	Einheit
1	5.023-650.0	Blechteil (SP)	1.000	ST
2		Gas Set KM	1.000	ST
4	5.058-622.0	Blechteil Halter Schottverschraubung (SP)	1.000	ST
5	5.058-613.0	Blechteil	1.000	ST
10	6.395-035.0	Anschluss Gasflasche	1.000	ST
11	6.390-987.0	HD-Schlauch	1.000	ST
12	6.385-805.0	Winkelstueck	2.000	ST
13	6.368-301.0	Schottverschraubung	1.000	ST
14	4.025-782.0	Rohr kpl. Gas	1.000	ST
15	6.395-033.0	Reduziernippel	1.000	ST
16	6.686-116.0	Magnetventil LPG Absperrventil	1.000	ST
17	6.395-034.0	Reduziernippel	1.000	ST
18	6.421-213.0	Dichtring ID12 AD18 AL J22	1.000	ST
19	6.635-363.0	Druckregler	1.000	ST
20	6.491-624.0	Choke L237	1.000	ST
21	6.390-291.0	Schlauch 9,0x14	1.000	ST
22	7.373-019.0	Schlauchschele A 10-16x9-W4 DIN3017	2.000	ST
23	6.391-058.0	Schlauch 5.5x10.5	1.000	ST
24	6.388-522.0	Schlauchschele	2.000	ST
25	6.641-641.0	Durchfuehrungstuelle D32	2.000	ST
26	6.373-212.0	Rohrschele	2.000	ST
27	6.390-276.0	Schlauchnippel	1.000	ST
28	6.368-300.0	Schutzkappe KMR 1550 LPG UBS	1.000	ST
30	6.303-109.0	Schraube SPAX 5x20-ST-A2E	6.000	ST
32	7.304-417.0	6kt-Schraube M10x30-8.8-A3E ISO 4017	4.000	ST
33	7.312-005.0	Scheibe 10-200HV-A3E ISO 7090	8.000	ST
34	7.311-511.0	6kt-Mutter M10-8-A2E ISO 7040	4.000	ST
35	6.303-031.0	Schraube M8x16-ST-R2R DIN 7500-1	2.000	ST
38	6.368-064.0	Verschlussstopfen	2.000	ST
39	6.365-498.0	Dichtungsprofil	1.000	M
41	6.631-950.0	Schalter	1.000	ST
42	7.314-127.0	Zylinderstift 3h11x5 -Cu2 ISO 2338	1.000	ST
43	7.314-144.0	Zylinderstift 4m6x6-St ISO 2338	1.000	ST

190 UBS KM 100/100 R LPG

POS	Artikelnr.	Beschreibung	Anzahl	Einheit
44	7.314-081.0	Zylinderstift 3m6x12-St ISO 2338	1.000	ST
45		Kabel	1.000	ST
46	6.641-464.0	Kabelbinder	5.000	ST
47	6.365-374.0	Dichtungsprofil	0.800	M
53	6.282-033.0	Lecksuchspray	1.000	ST
54	6.869-070.0	Metallkleber	1.000	ZST

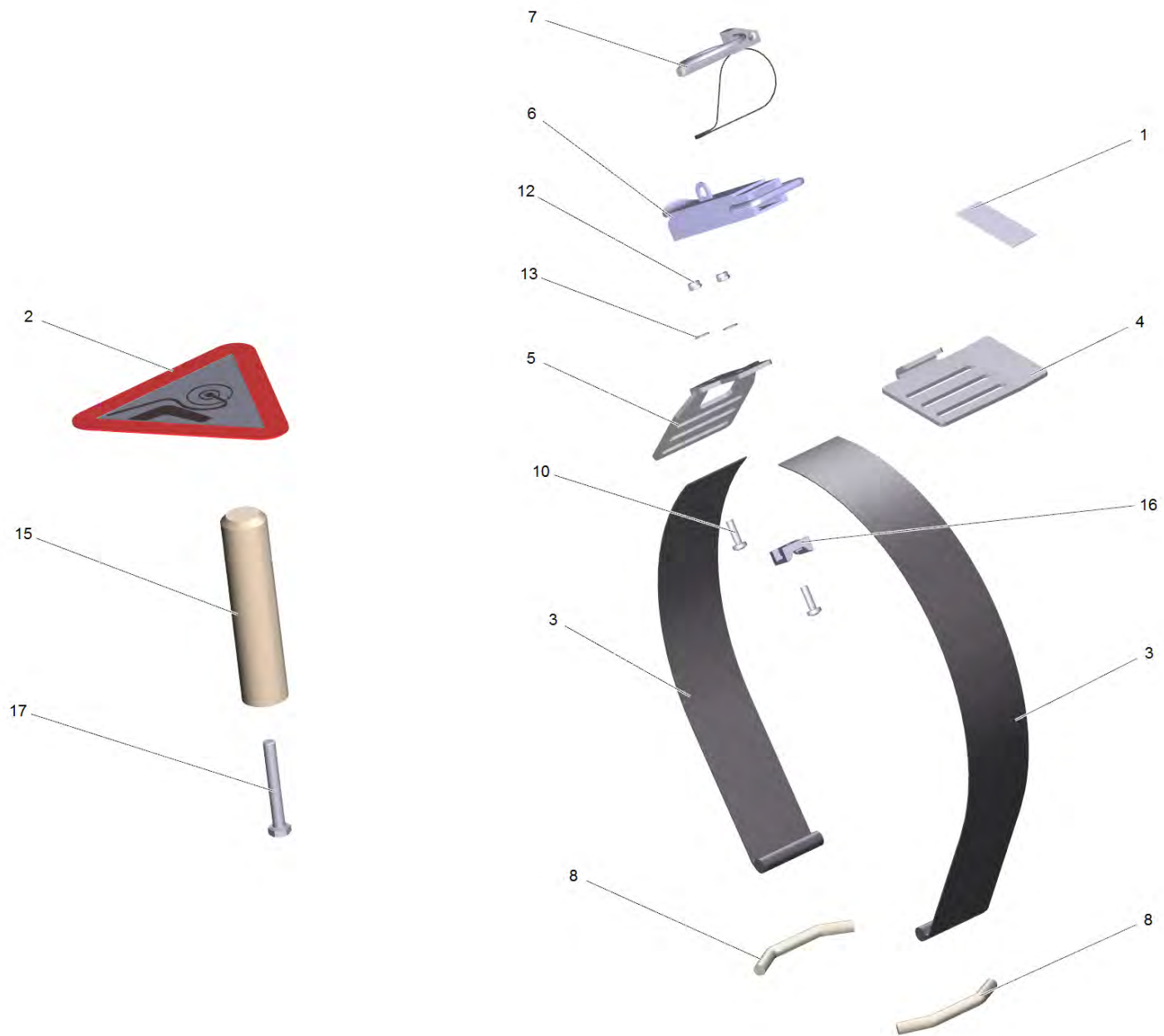

2 Gas Set KM

POS	Artikelnr.	Beschreibung	Anzahl	Einheit
1	5.237-015.0	Aufkleber Sicherheitsverschluss LPG	1.000	ST
2	6.376-487.0	Schild	1.000	ST
3	6.277-048.0	Gurt Set Lpg	2.000	ST
4	4.058-812.0	Blechteil Haken	1.000	ST
5	4.058-811.0	Blechteil Spannverschluss	1.000	ST
6	6.375-002.0	Spannverschluss LPG	1.000	ST
7	7.316-470.0	Klappstecker 8x42-St-A2E DIN 11023	1.000	ST
8	5.316-012.0	Bolzen Spannverschluss Lpg	2.000	ST
10	7.306-077.0	Schraube M5x16 -8.8-R2R (In6Rd)	2.000	ST
11	7.312-052.0	Scheibe 5 -A2 ISO 7089	2.000	ST
12	7.311-431.0	6kt-Mutter M 5-1.4305 ISO 10511	2.000	ST
13	6.437-666.0	Seil mit Schlaufen	1.000	ST
14	5.111-557.0	Bolzen Positionierung LPG	1.000	ST
15	7.304-401.0	6kt-Schraube M 8x60-8.8-A2E ISO 4017	1.000	ST
16	6.648-602.0	Halter	1.000	ST

16 Magnetventil LPG Absperrventil (6.686-116.0)

POS	Artikelnr.	Beschreibung	Anzahl	Einheit
10	6.686-612.0	Ersatzteil Absperrventil Magnetventil	1.000	ST

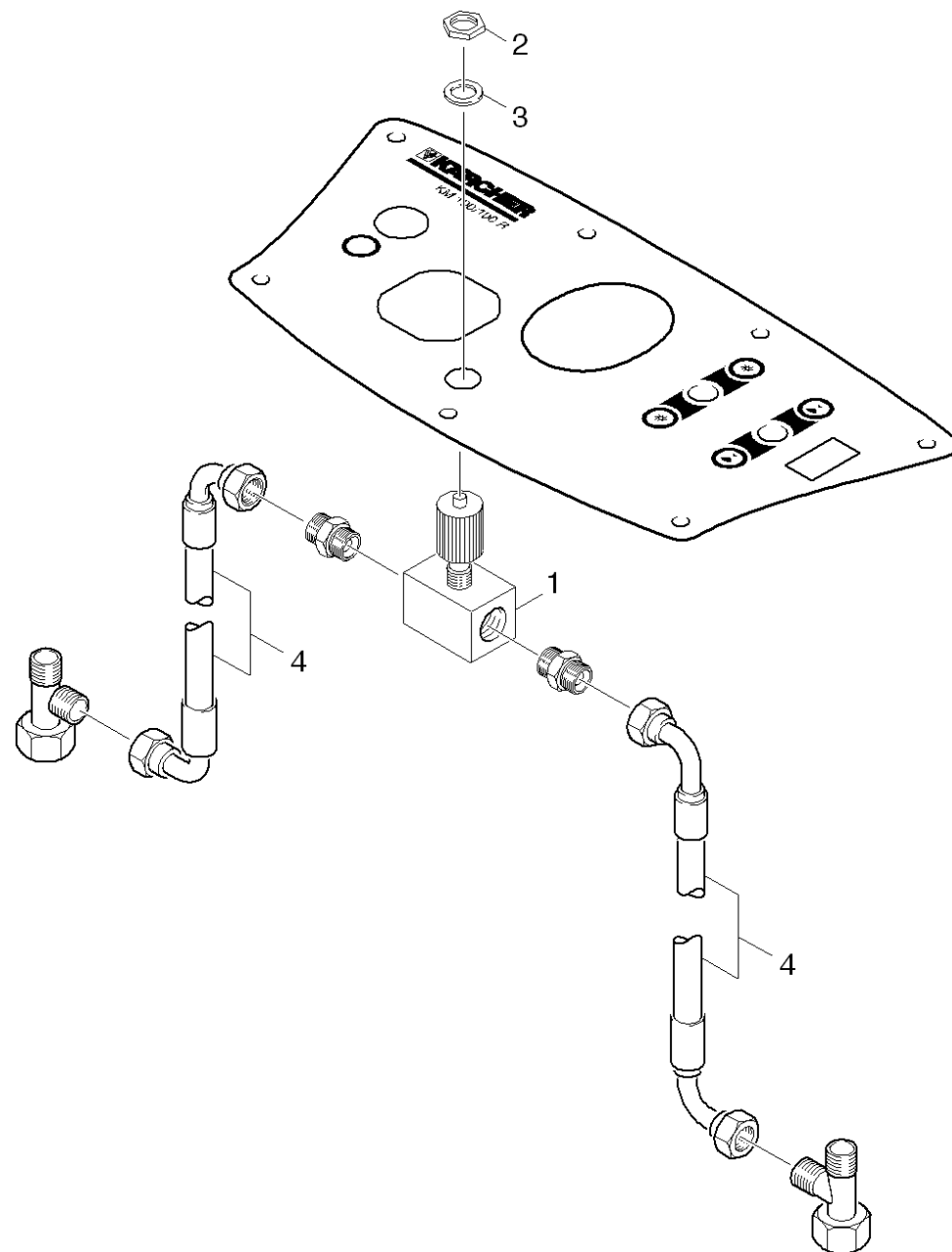

200 ABS Besen Steuerung

POS	Artikelnr.	Beschreibung	Anzahl	Einheit
1	6.413-447.0	Drosselventil NDV	1.000	ST
2	6.641-482.0	Gegenmutter PG11	1.000	ST
3		Scheibe 18 -A2 ISO 7090	1.000	ST
4	6.391-507.0	Hydraulikschlauch	2.000	ST

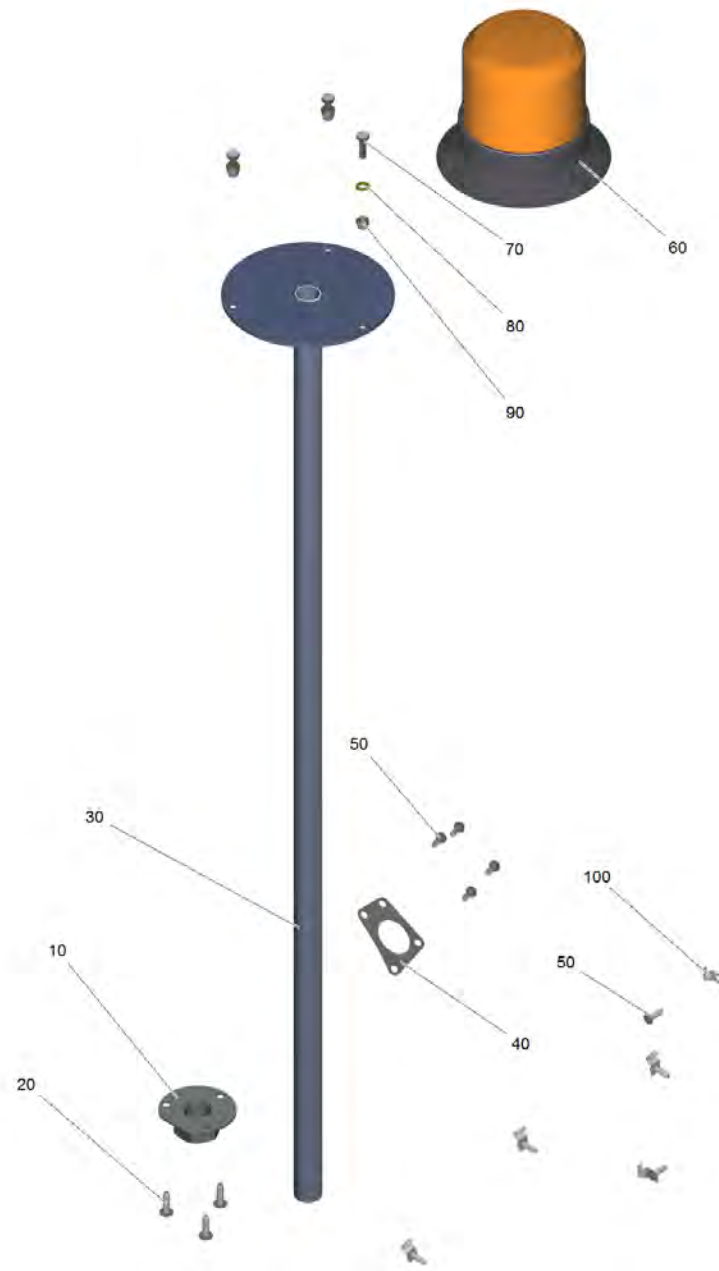

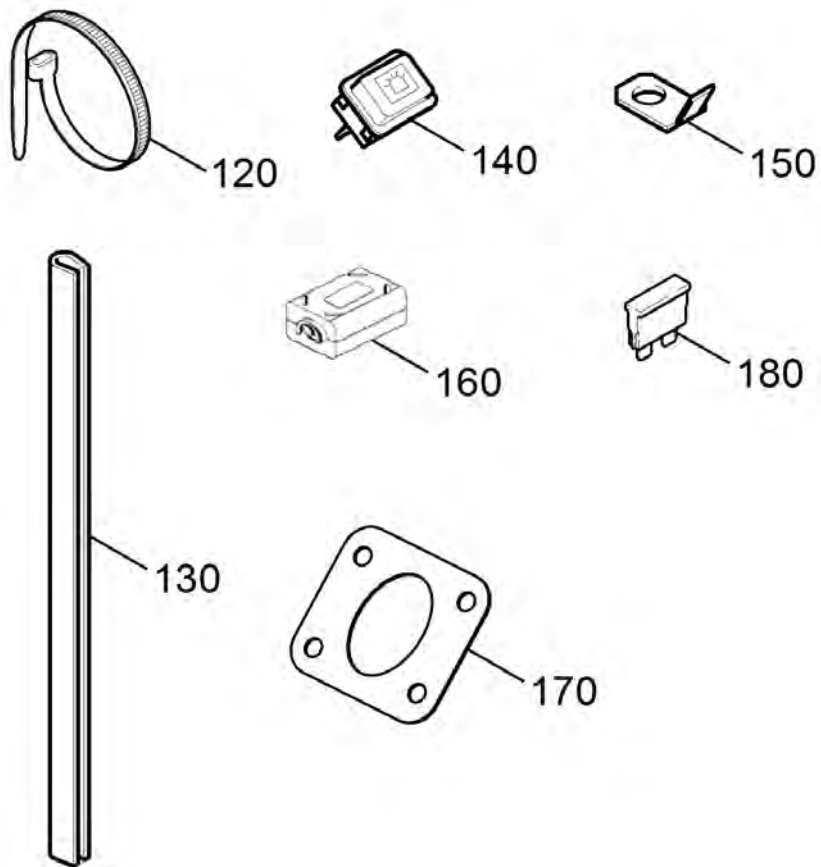
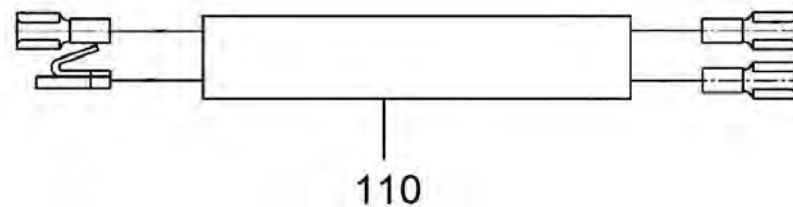

210 ABS Rundumkennleuchte LED KM 90/60 (2.643-887.0)

POS	Artikelnr.	Beschreibung	Anzahl	Einheit
10		Gegenhalter Rundumkennleuchte	1.000	ST
20	7.303-112.0	Schraube 6x20 -10.9-R2R (In6Rd)	3.000	ST
30		Halter Rundumkennleuchte LED	1.000	ST
40	5.062-430.0	Blech Abdeckung Rundumkennleuchte	1.000	ST
50	7.303-107.0	Schraube 5x16 -10.9-P2R (K-In6Rd)	11.000	ST
60		Rundumkennleuchte LED kpl.	1.000	ST
70	7.304-536.0	6kt-Schraube M 6x20-A4-70 ISO 4017	3.000	ST
80	7.312-045.0	Scheibe 6-200HV-P4E ISO 7089	3.000	ST
90	7.311-512.0	6kt-Mutter M 6-8-A2E ISO 7040	3.000	ST
100	7.373-000.0	Schelle 1-6-W1-2 DIN 72571	5.000	ST
110	2.820-271.0	Kabelsatz Rundumkennleuchte	1.000	ST
120	6.641-464.0	Kabelbinder	12.000	ST
130	6.368-106.0	Kantenschutz	0.110	M
140	6.632-476.0	Schalter 2-polig Leuchte	1.000	ST
150	6.647-577.0	Flachstecker	1.000	ST
160	6.640-295.0	Ferritkern	1.000	ST
170	5.010-066.0	Blech Abdeckung Rundumkennleuchte	1.000	ST
180	7.644-006.0	Sicherungseinsatz C 3 DIN 72581-3	1.000	ST

60 Rundumkennleuchte LED kpl.

POS	Artikelnr.	Beschreibung	Anzahl	Einheit
10	6.988-512.0	Rundumkennleuchte LED 10-100V	1.000	ST
20	6.648-280.0	Flachstecker AMP6.3 -0,4-1,6 mm	2.000	ST