

Ersatzteilliste

(1.148-472.0) NT 50/1 Mwf *EU

Inhaltsverzeichnis

NT 50/1 Mwf *EU (1.148-472.0)	3
90 Gehaeuse Luftfuehrung Set (4.071-369.0)	13
102 Set Gehaeuse Grundplatte K/Mwf (4.101-162.0)	15
174 Drehgelenk Set (4.071-041.0)	17
321 Saugschlauch NT DN40 4m EC (2.889-141.0)	19
9000 Reparatur-Set NW40 (2.889-150.0)	21
325 Bodenduese (6.903-018.0)	23
9526 Verlaengerungsschlauch NT DN40 2.5m (2.889-146.0)	25

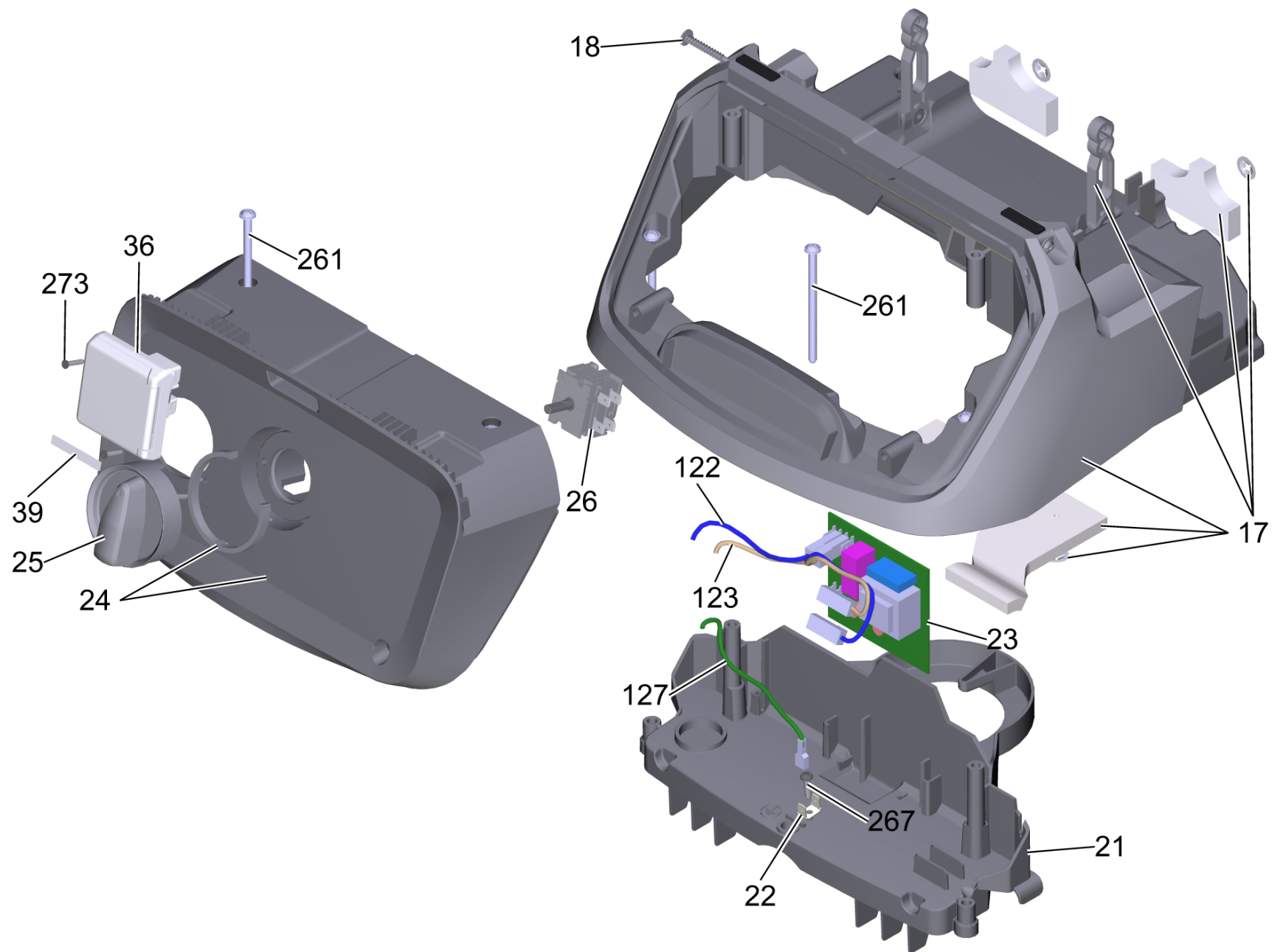

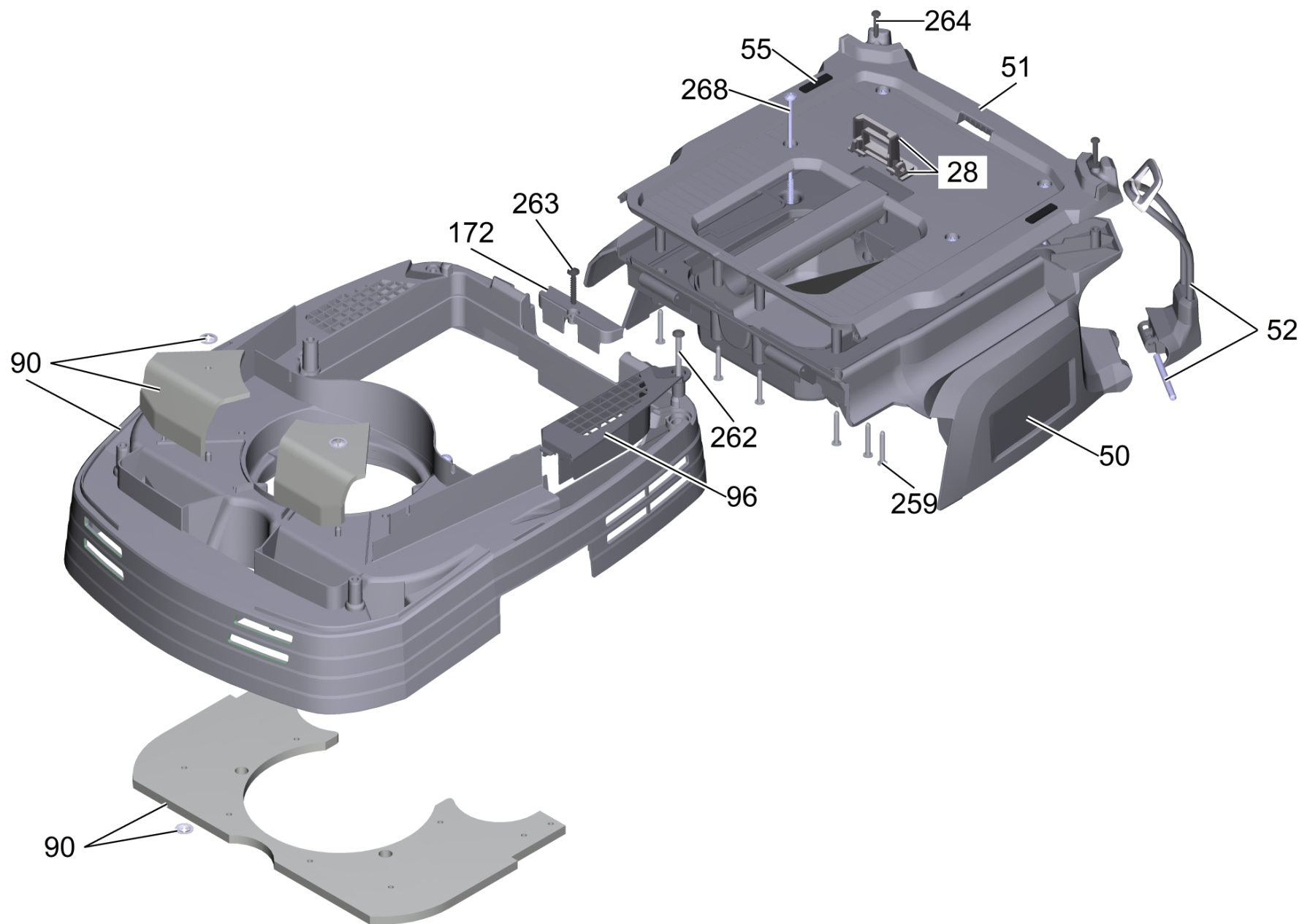

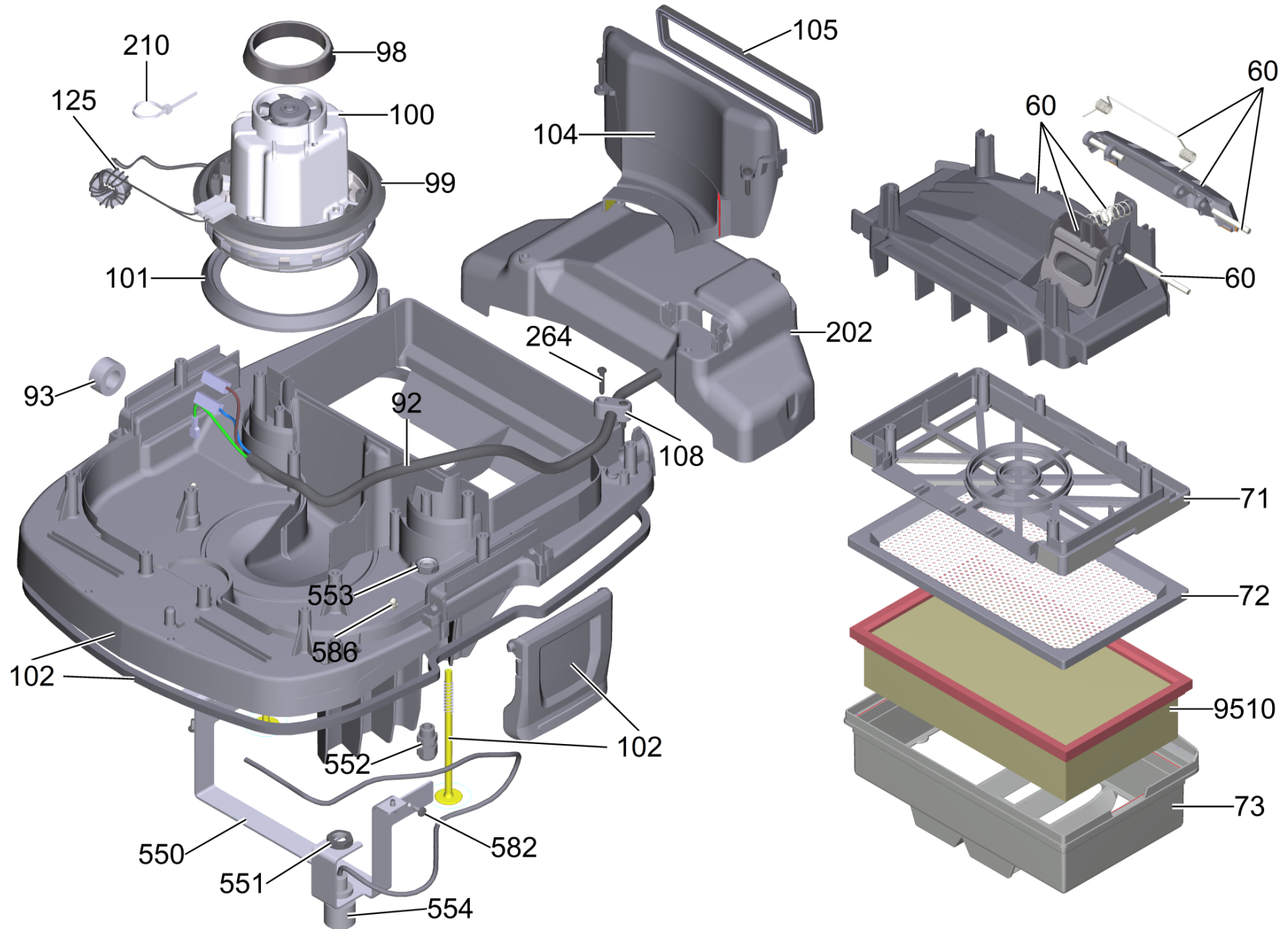

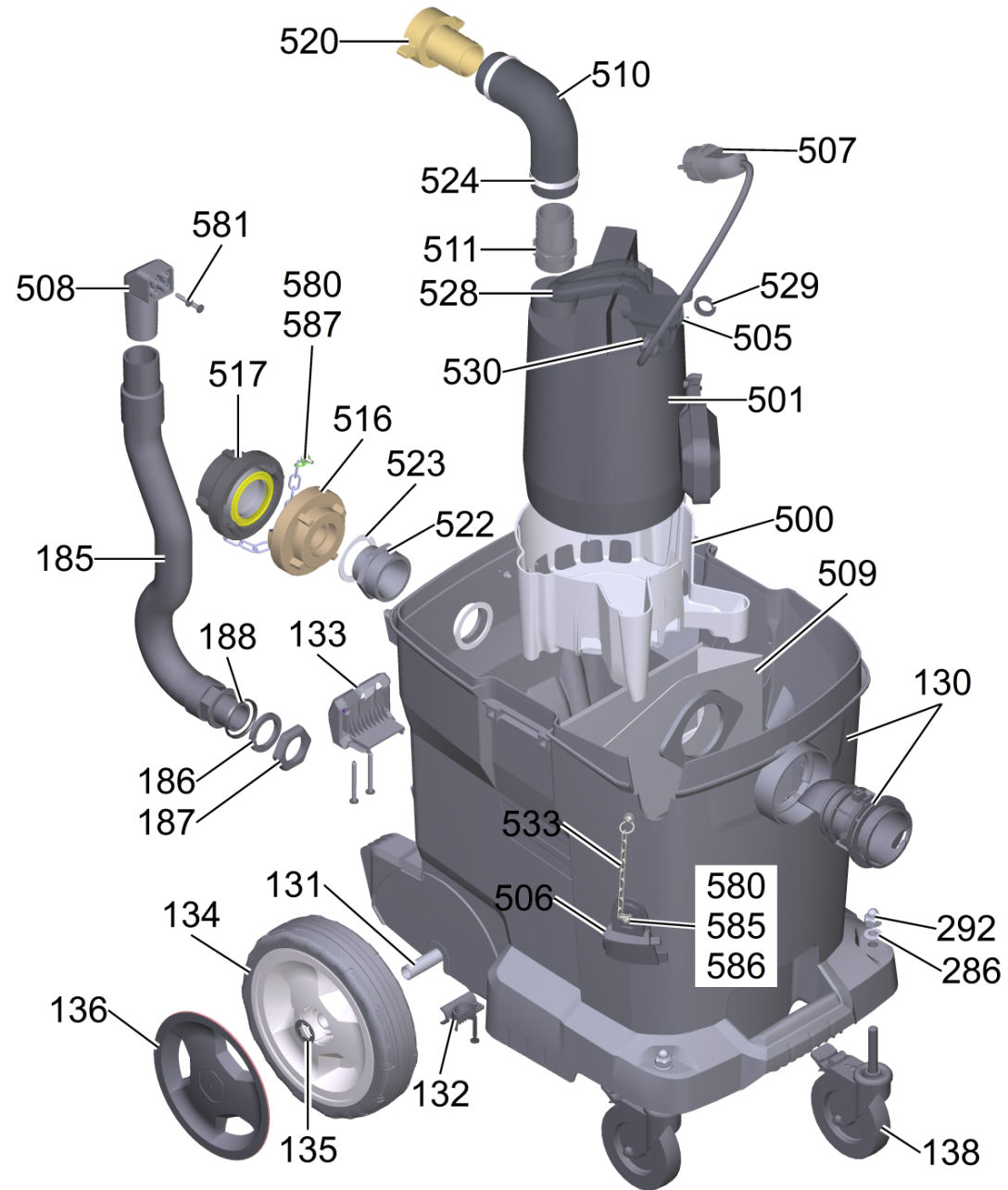

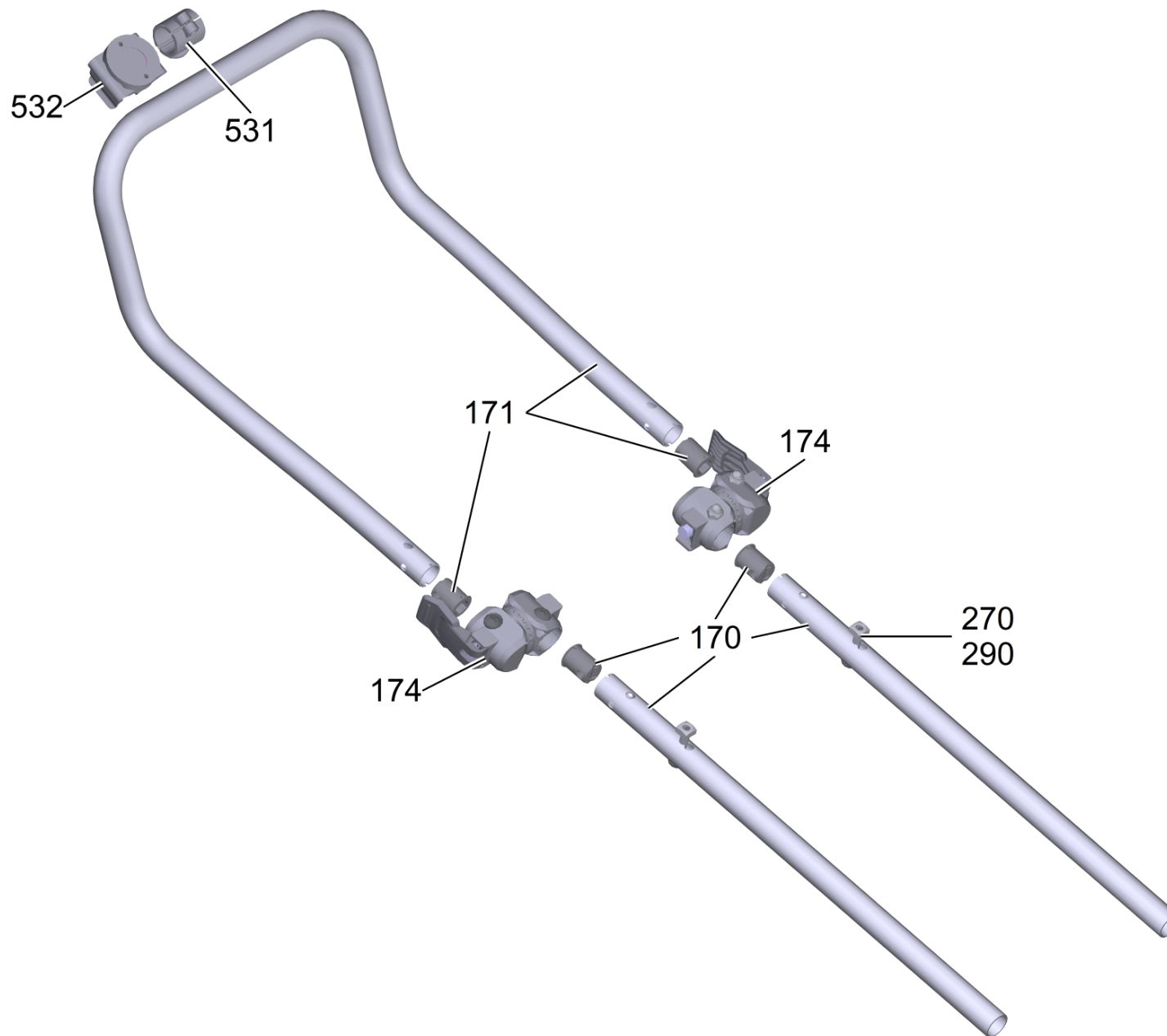



POS	Artikelnr.	Beschreibung	Anzahl	Einheit
17	4.101-160.0	Set Haube NT 50/1	1	ST
18	5.107-004.0	Fuehrungsschraube	2	ST
21	5.605-056.0	Gehaeuse Luftfuehrung oben Ap	1	ST
22	6.649-914.0	Flachstecker	1	ST
23	6.682-705.0	Schaltelektronik	1	ST
24	4.101-161.0	Set Instrumententafel NT 50/1	1	ST
25	4.071-393.0	Drehgriff fuer Ersatz	1	ST
26	4.071-389.0	Drehschalter Ersatz Ap	1	ST
28	4.070-345.0	Fixierung Koffer	1	ST
36	6.645-834.0	Steckdose *EU	1	ST
39	4.071-485.0	Schild Steckdose 1100W	1	ST
50	4.071-022.0	Filterdeckel Set NT Tact	1	ST
51	4.071-318.0	Filterdeckel Oberteil Set Ap	1	ST
52	4.071-811.0	Set Haken kpl.	2	ST
55	4.071-368.0	Antirutschgummi Set	4	ST
60	4.101-052.0	Filterdeckel kpl.	1	ST
71	5.064-056.3	Halter Flachfilter	1	ST
72	6.904-287.0	Grobschmutzfilter verpackt	1	ST
73	5.064-055.0	Rahmen Flachfaltenfilter	1	ST
90	4.071-369.0	Gehaeuse Luftfuehrung Set	1	ST
92	6.652-171.3	Netzanschlusskabel mit PRCD-K *EU	1	ST
93	6.346-043.0	Ferritring	1	ST
96	5.605-058.0	Deckel Gehaeuse Luftfuehrung	1	ST
98	5.363-735.0	Dichtung Saugturbine oben	1	ST
99	5.363-795.0	Dichtung Saugturbine mitte	1	ST
100	6.490-245.0	Geblaesemotor 230V	1	ST
101	5.363-256.0	Dichtung unten	1	ST
102	4.101-162.0	Set Gehaeuse Grundplatte K/Mwf	1	ST
104	5.064-057.0	Luftfuehrung	1	ST
105	5.363-187.0	Dichtung Zuluft	1	ST
108	5.031-474.0	Zugentlastung Tact	1	ST
122	6.652-173.0	Aderleitung doppelt blau	1	ST
123	6.652-174.0	Aderleitung doppelt braun	1	ST

POS	Artikelnr.	Beschreibung	Anzahl	Einheit
125	6.650-667.0	Kabel Turbine	2	ST
127	6.650-672.0	Kabel gruen/gelb 1,5mm²x180mm	1	ST
130	5.070-288.3	Behaelter 50l K/Mwf	1	ST
131	5.105-025.0	Achse	1	ST
132	5.044-456.0	Halter Achse	2	ST
133	5.044-317.0	Halter Bodenduese	1	ST
134	5.515-088.0	Rad D220	2	ST
135	6.343-168.0	Sicherungsscheibe	2	ST
136	5.515-093.0	Radkappe gross RAL 7012	2	ST
138	6.435-896.0	Lenkrolle mit Bremse Ø100	2	ST
170	4.071-385.0	Schubbuegel unten Set	2	ST
171	4.071-386.0	Schubbuegel oben Set	1	ST
172	5.034-096.0	Blende Halter Zubehoer	1	ST
174	4.071-041.0	Drehgelenk Set	4	ST
185	6.391-002.0	Ablassschlauch DN 32 NT 611 ECO	1	ST
186	6.363-250.0	Dichtring 32x44	1	ST
187	5.031-940.0	Sechskantmutter	1	ST
188	9.411-023.3	Ring	1	ST
202	4.071-424.0	Luftfuehrung fuer Ersatz	1	ST
210	6.388-055.0	Einohrschelle Ø51,5mm	1	ST
259	7.303-285.0	Schraube 4x30-10.9-R2R (K-In6Rd)	6	ST
261	7.303-171.0	Schraube 5x80 -10.9-R2R (K-In6Rd)	10	ST
262	7.303-111.0	Schraube 5x50 -10.9-R2R (K-In6Rd)	4	ST
263	7.303-086.0	Schraube 5x30 -10.9-R2R (K-In6Rd)	5	ST
264	7.303-096.0	Schraube 4x22-ST-10.9-R2R (IN6RD)	6	ST
267	7.303-129.0	Schraube 4x16-10.9-R2R (K-In6Rd)	3	ST
268	7.303-323.0	Schraube 5x130-10.9-R2R (K-In6Rd)	4	ST
270	6.303-285.0	Schraube M 8x 40	2	ST
272	7.303-206.0	Schraube 3,5x16-10.9-P2R (In6Rd)	2	ST
286	7.312-066.0	Scheibe 10 -A2 ISO 7089	2	ST
290	7.311-570.0	4kt-Mutter M8 -05-A2E DIN 557	2	ST
292	7.311-621.0	Hutmutter M10-A2 DIN 986	2	ST
320	2.889-171.0	Kruemmer verpackt NW40 1K	1	ST

POS	Artikelnr.	Beschreibung	Anzahl	Einheit
320	2.889-172.0	Kruemmer elektr. leitend NW40 1K	1	ST
321	2.889-140.0	Saugschlauch NT DN40 4m OR	1	ST
321	2.889-141.0	Saugschlauch NT DN40 4m EC	1	ST
322	2.889-194.0	Saugrohr 2x NT DN40 550mm StSt	1	ST
325	6.903-018.0	Bodenduese	1	ST
326	2.889-160.0	Fugenduese NT verpackt NW40	1	ST
500	4.071-827.0	Traeger Pumpe Mast	1	ST
501	6.473-472.0	Tauchmotorpumpe	1	ST
505	5.038-629.0	Adapter mit Loch	1	ST
506	5.038-628.0	Adapter ohne Loch	1	ST
507	6.646-124.0	Stecker	1	ST
508	9.412-338.0	Formteil	1	ST
509	5.731-079.3	Filterkorb fuer Ersatz	1	ST
510	5.408-027.0	Rohrkruemmer Mast	1	ST
511	5.443-072.0	Schlauchnippel	1	ST
516	6.391-333.0	Schlauchkupplung C	1	ST
517	7.545-011.0	Blindkupplung C-3.2315.61P DIN14311	1	ST
520	6.391-173.0	Schlauchverschraubung	1	ST
522	5.471-112.0	Kupplungsteil	1	ST
523	6.362-036.0	Dichtung 42 X 56	2	ST
524	6.388-055.0	Einohrschelle Ø51,5mm	2	ST
528	6.645-489.0	Kabelschutzschlauch 21mm	0,25	m
529	6.648-415.0	Gegenmutter schwarz M16	1	ST
530	4.071-832.0	Kabelverschraubung schwarz M16x1,5	1	ST
531	6.373-050.0	Rohrbefestigung Toolflex	1	ST
532	6.373-172.0	Halterung Micky Clip	1	ST
533	6.391-234.0	Kette mit Haken	1	ST
550	4.071-826.0	Blechteil Halter Schwimmer	1	ST
551	6.641-756.0	Gegenmutter PG 7	1	ST
552	6.641-208.0	Kabelverschraubung M12x1,5 PA	1	ST
553	6.648-406.0	Gegenmutter grau M12	1	ST
554	6.631-123.3	Schwimmerschalter	1	ST
580	7.306-058.0	Schraube M 4X 12- 8.8-R2R K-IN6RD	3	ST

NT 50/1 Mwf *EU (1.148-472.0)

POS	Artikelnr.	Beschreibung	Anzahl	Einheit
581	7.303-108.0	Schraube 5x20 -10.9-R2R (In6Rd)	2	ST
582	7.303-030.0	Schraube M4x8 -St-P2R (In6Rd)	4	ST
585	7.312-293.0	Scheibe 4-A2 ISO 7093-1	3	ST
586	7.311-399.0	Hutmutter M4 -CuZn-E2E DIN 1587	7	ST
587	7.312-292.0	Scheibe 6 -A2 ISO 7093-1	1	ST
9500	2.885-890.0	Power Tool Adapter DN40	1	ST
9504	5.407-006.0	Anschluss Konus NW40	1	ST
9507	2.414-000.0	Kerzenfilter verpackt	1	ST
9508	6.596-886.0	Beutel 10 Stck. PE-NT35/1 NT45/1	1	ST
9509	6.907-480.0	Vlies-Filtertueten 5x NT	1	ST
9510	6.907-662.0	Flachfaltenfilter verpackt PES	1	ST
9526	2.889-146.0	Verlaengerungsschlauch NT DN40 2.5m	1	ST
9530	2.840-095.0	Autoduese verpackt NW 40	1	ST
9531	2.885-889.0	Muffe Falschlufklappe DN40	1	ST

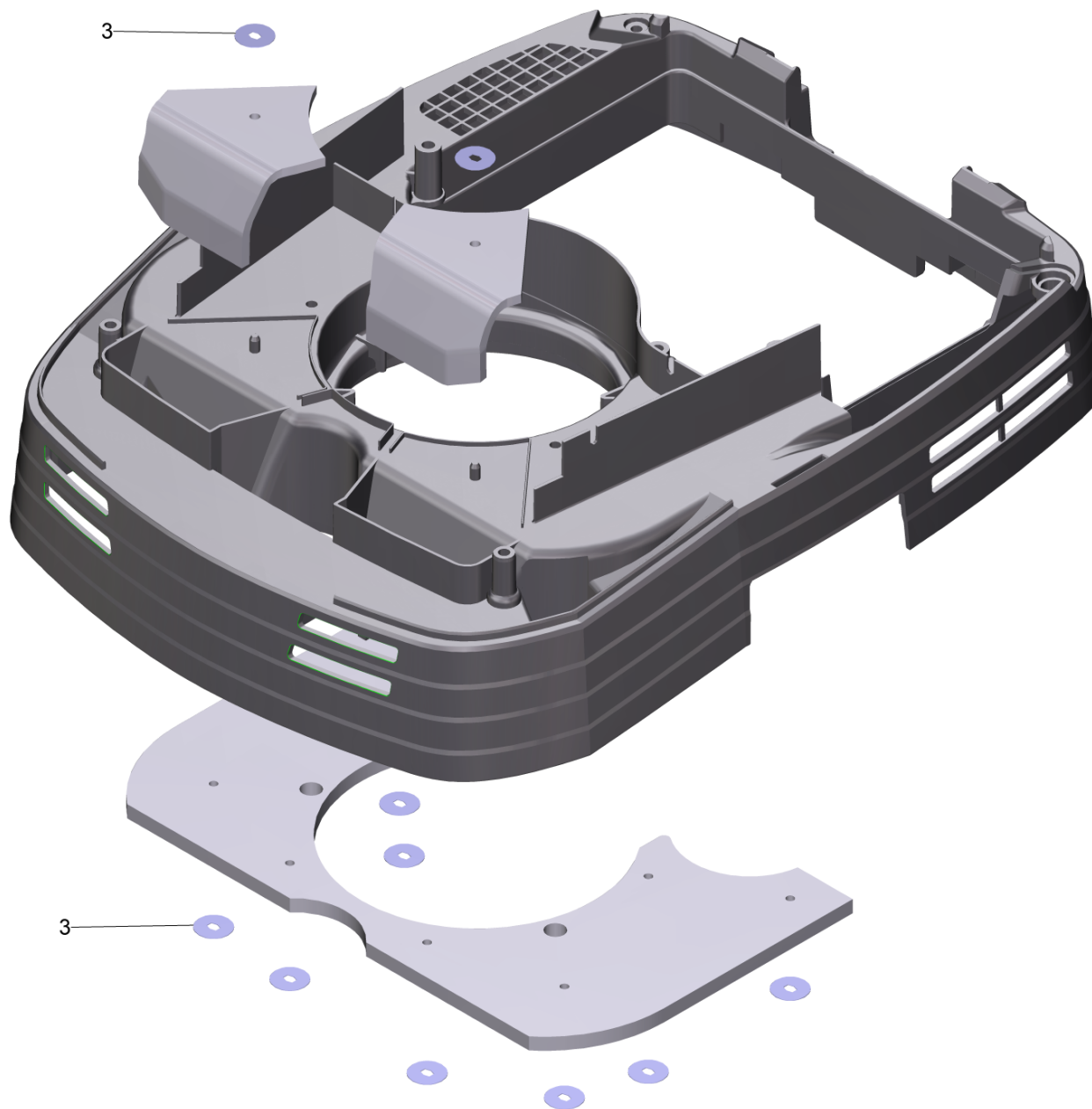

90 Gehäuse Luftführung Set (4.071-369.0)

POS	Artikelnr.	Beschreibung	Anzahl	Einheit
3	4.071-451.0	Sicherungsscheibe Ø 4,8x19	10	ST

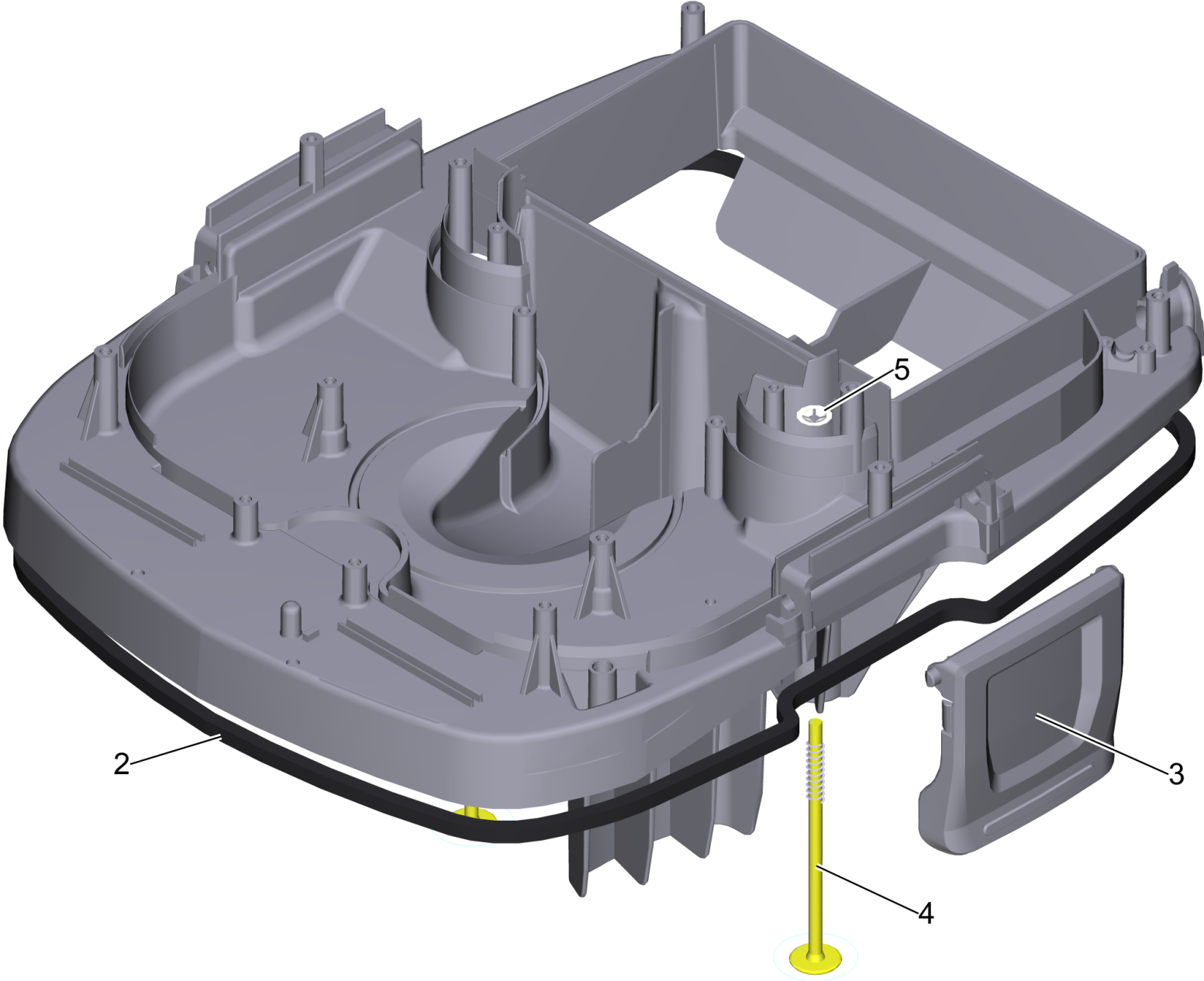

102 Set Gehaeuse Grundplatte K/Mwf (4.101-162.0)

POS	Artikelnr.	Beschreibung	Anzahl	Einheit
2	6.273-018.3	Dichtschnur Gehaeuse Grundplatte	1	ST
3	5.033-034.0	Verschlusslasche	2	ST
4	5.107-002.0	Sonde	2	ST
5	6.343-145.0	Sicherungsscheibe 5	2	ST

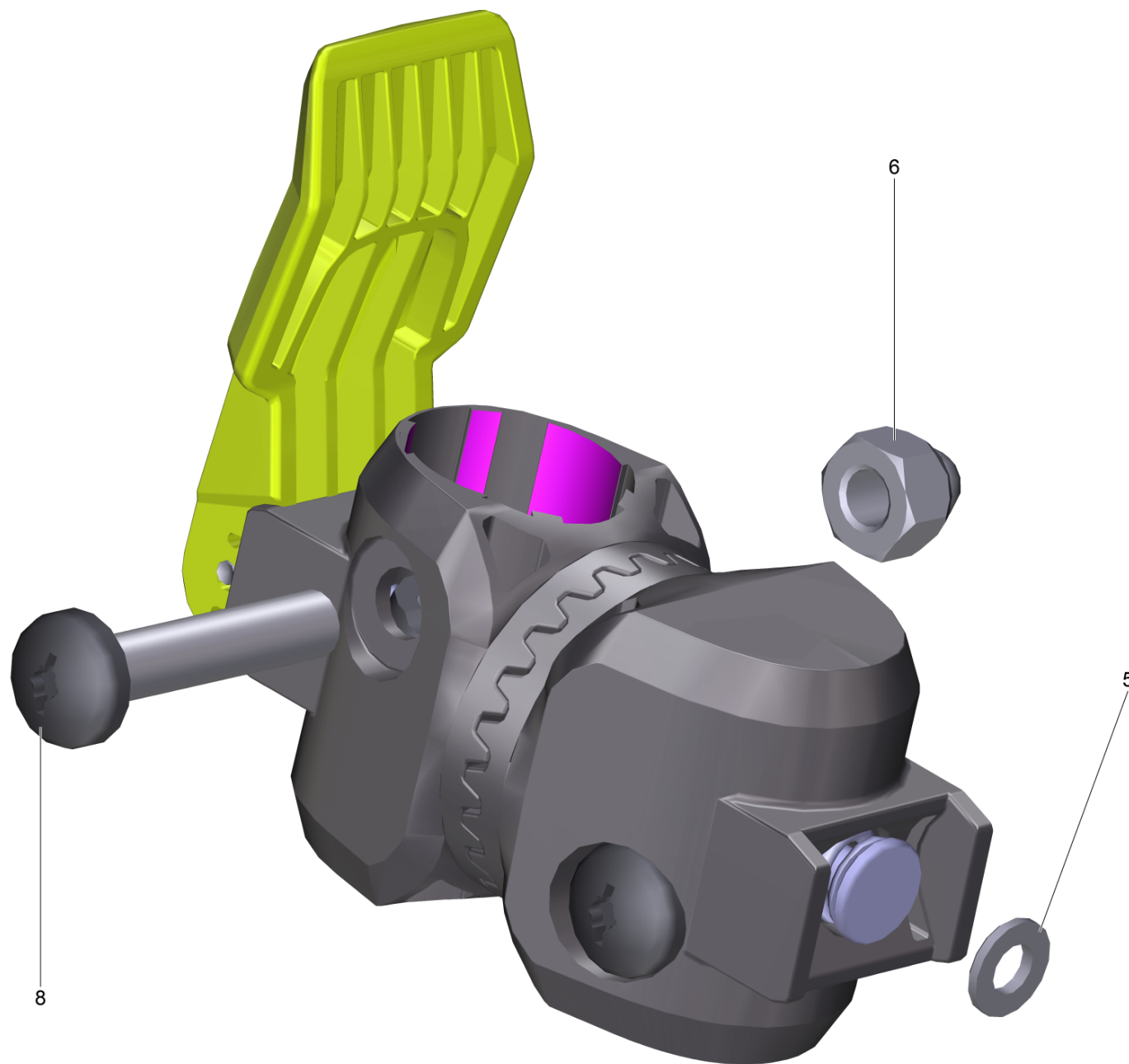

174 Drehgelenk Set (4.071-041.0)

POS	Artikelnr.	Beschreibung	Anzahl	Einheit
5	7.312-026.0	Scheibe 6 -A2 ISO 7089	2	ST
6	7.311-620.0	Hutmutter M8 -A2 DIN 986	4	ST
8	6.303-285.0	Schraube M 8x 40	4	ST

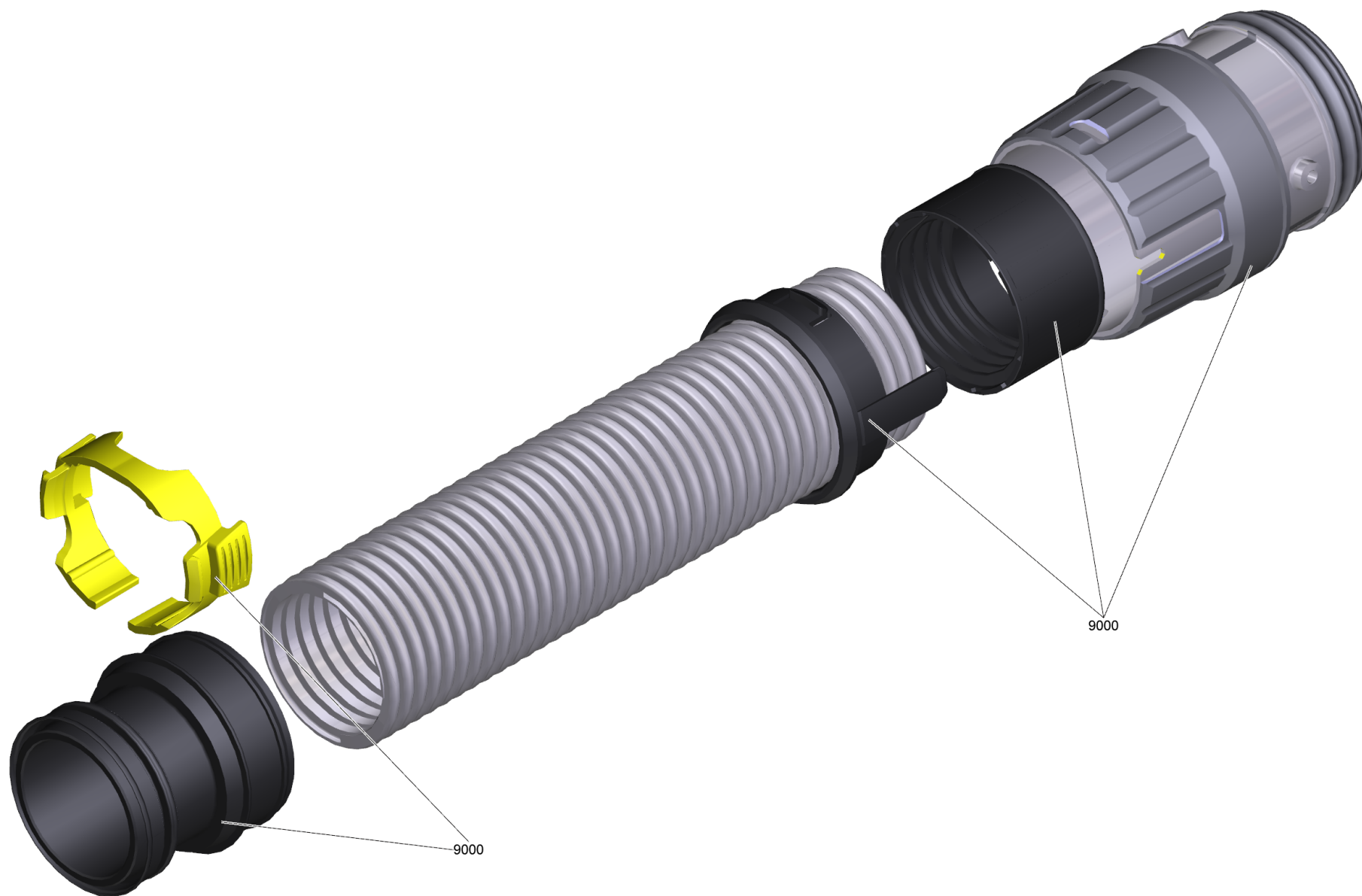

321 Saugschlauch NT DN40 4m EC (2.889-141.0)

POS	Artikelnr.	Beschreibung	Anzahl	Einheit
9000	2.889-150.0	Reparatur-Set NW40	1	ST



9000 Reparatur-Set NW40 (2.889-150.0)

POS	Artikelnr.	Beschreibung	Anzahl	Einheit
3	5.406-006.0	Gewinding elektr. leitend NW40	1	ST
5	5.031-213.0	Spannring NW40	1	ST

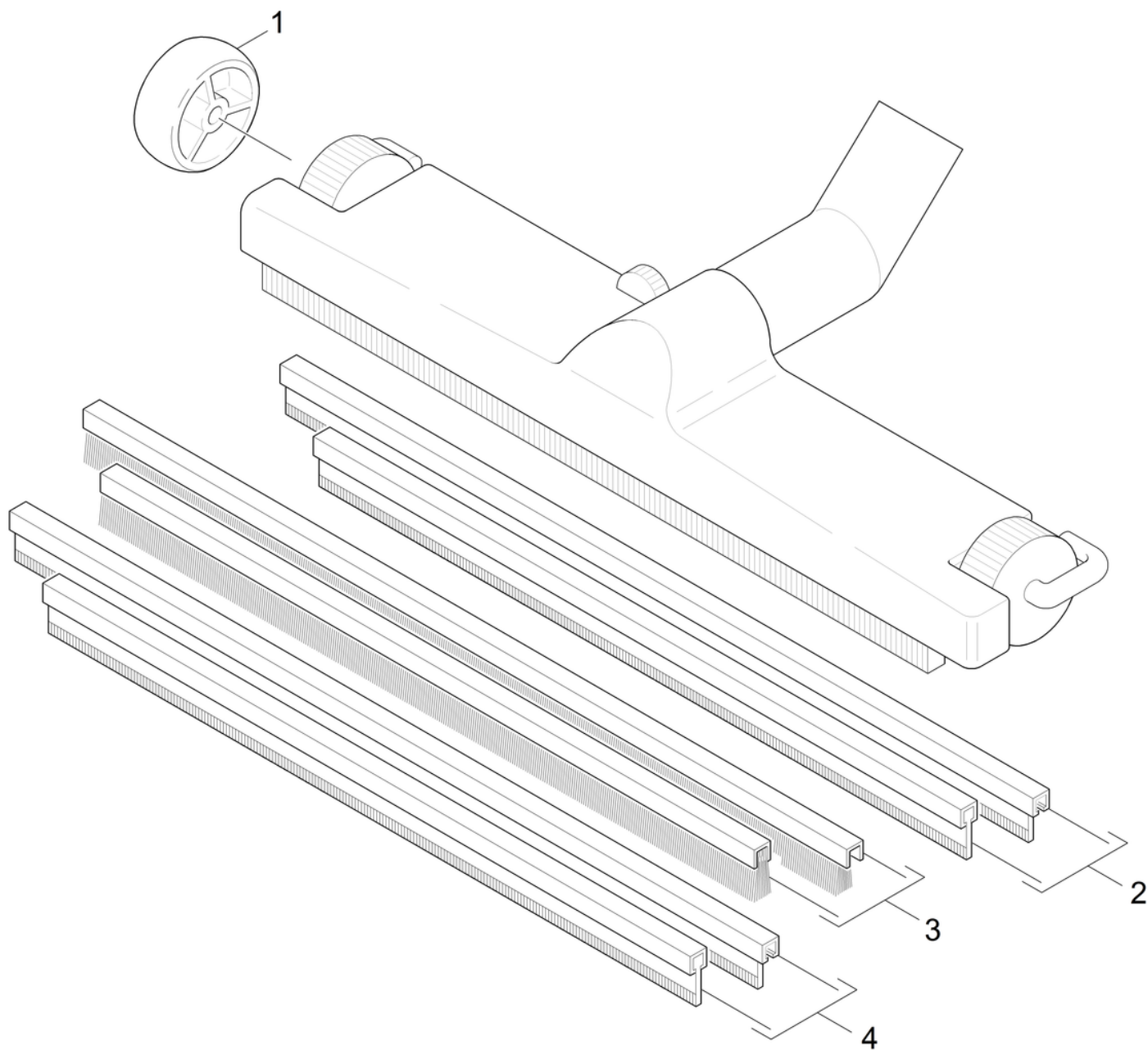

325 Bodenduese (6.903-018.0)

POS	Artikelnr.	Beschreibung	Anzahl	Einheit
1	6.903-016.0	Laufrolle	1	ST
2	6.903-062.0	Gummileistenset	1	ST
3	6.903-064.0	Buerstenstreifensatz	1	ST
4	6.903-081.0	Gummileistenset oelbestaendig	1	ST

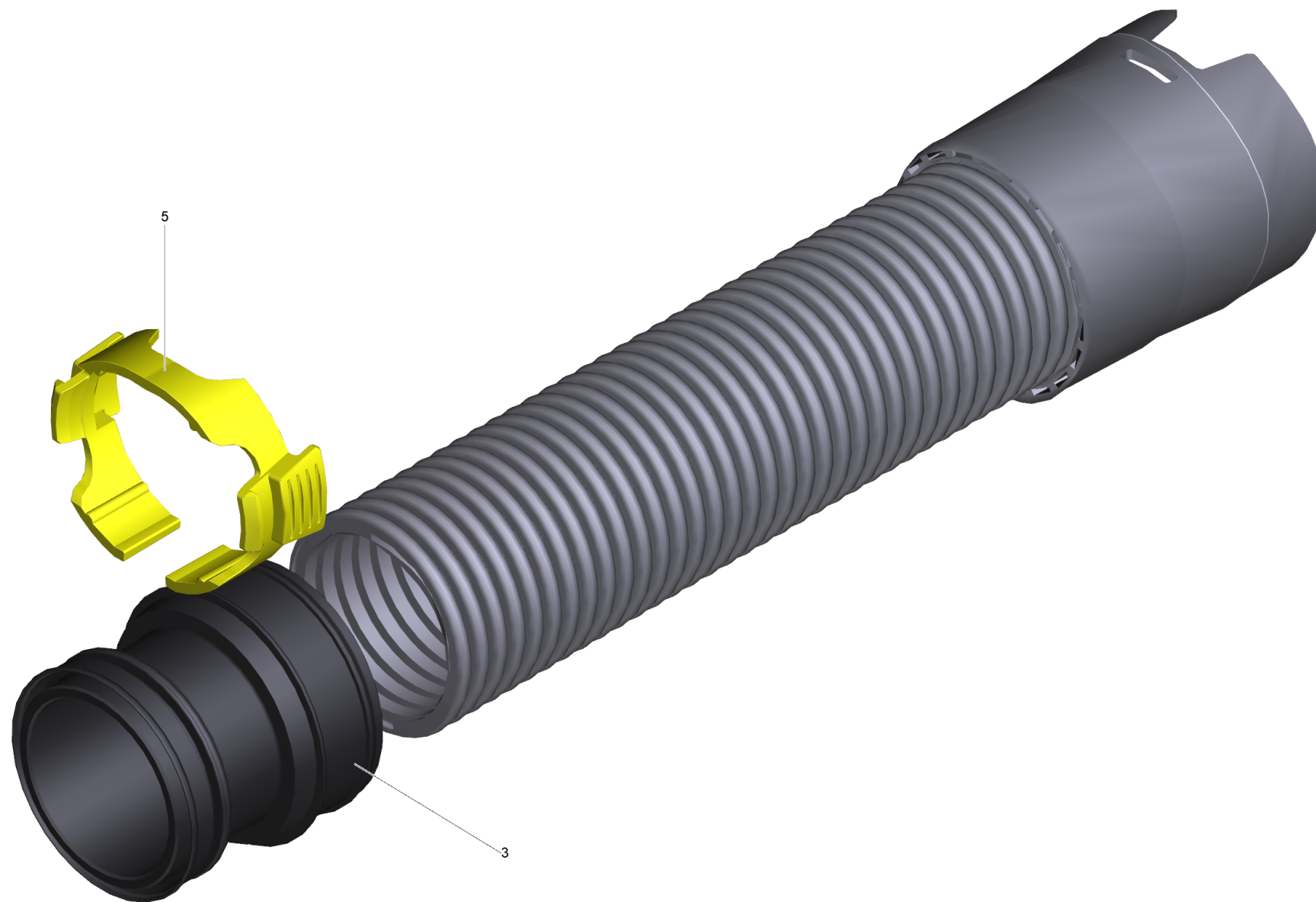

9526 Verlaengerungsschlauch NT DN40 2.5m (2.889-146.0)

POS	Artikelnr.	Beschreibung	Anzahl	Einheit
3	5.406-004.0	Gewinding NW40	1	ST
5	5.031-213.0	Spannring NW40	1	ST