

Ersatzteilliste

(1.528-121.0) T 9/1 Bp Pack *EU

Inhaltsverzeichnis

T 9/1 Bp Pack *EU (1.528-121.0)	3
79 Kruegger verpackt antistatisch NW35 2K (2.889-148.0)	10
80 Schlauch verpackt NW35 2.5m (2.889-133.0)	12
900 Adapter alt verpackt NW35 (2.889-312.0)	14

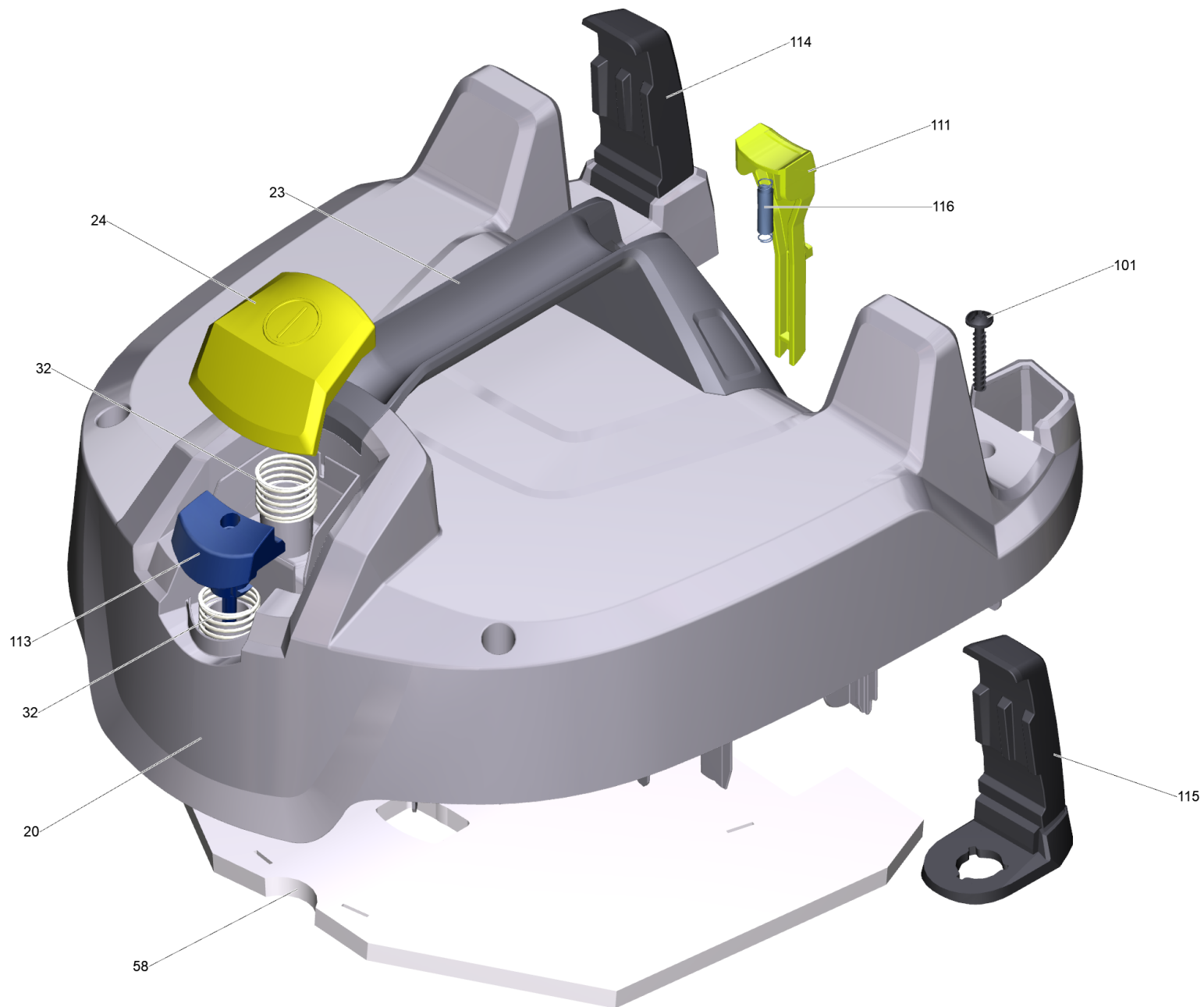

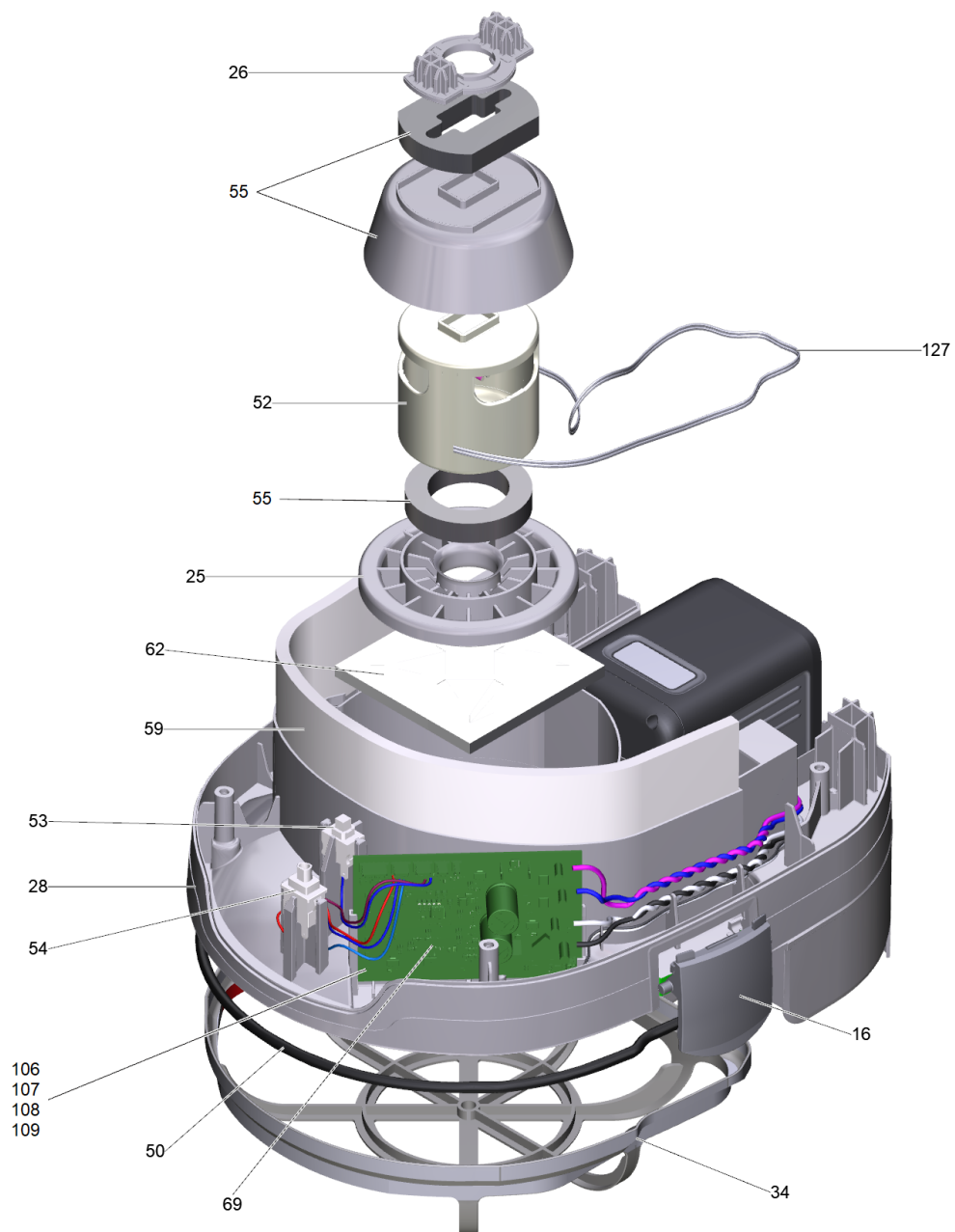

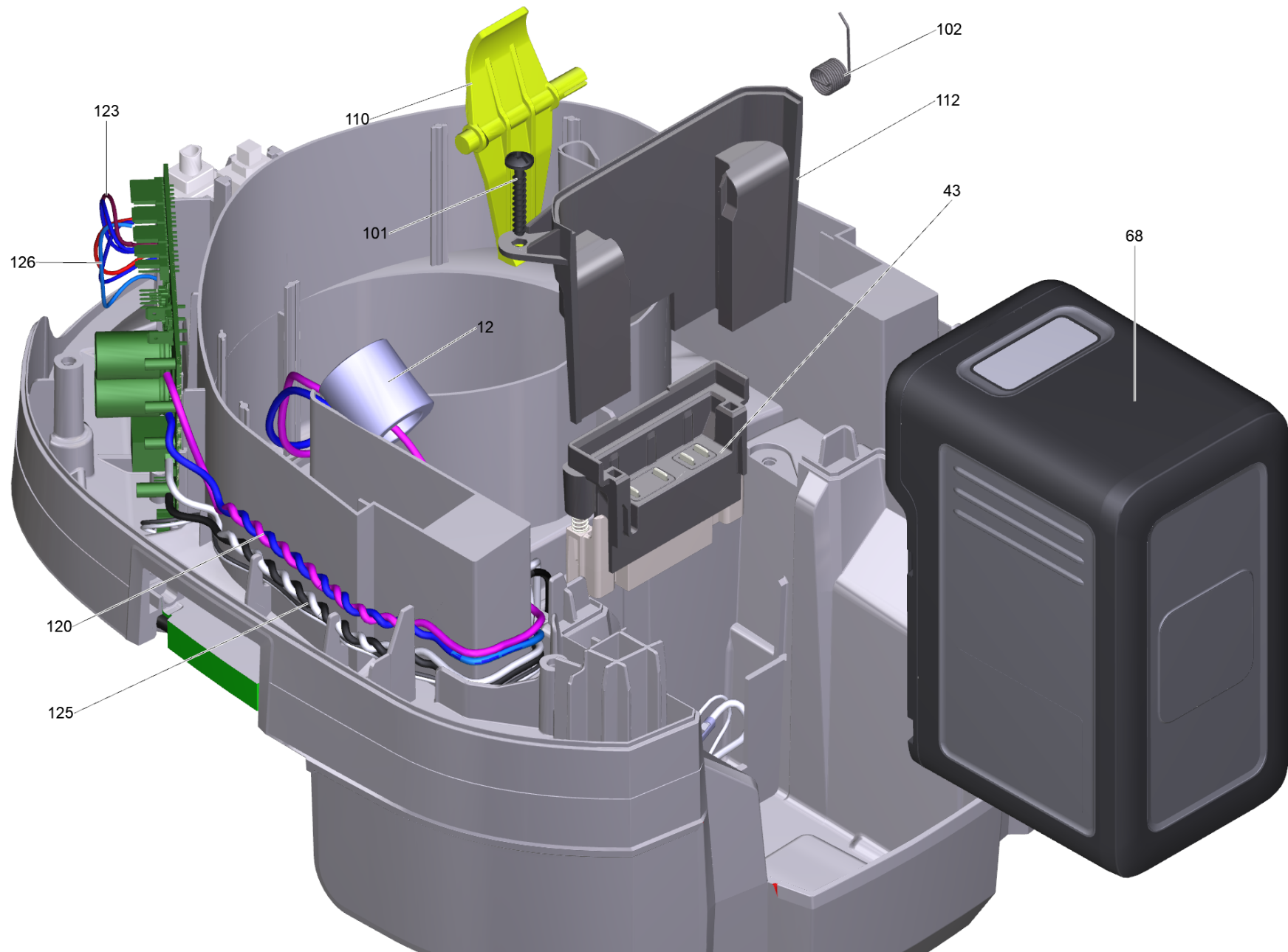

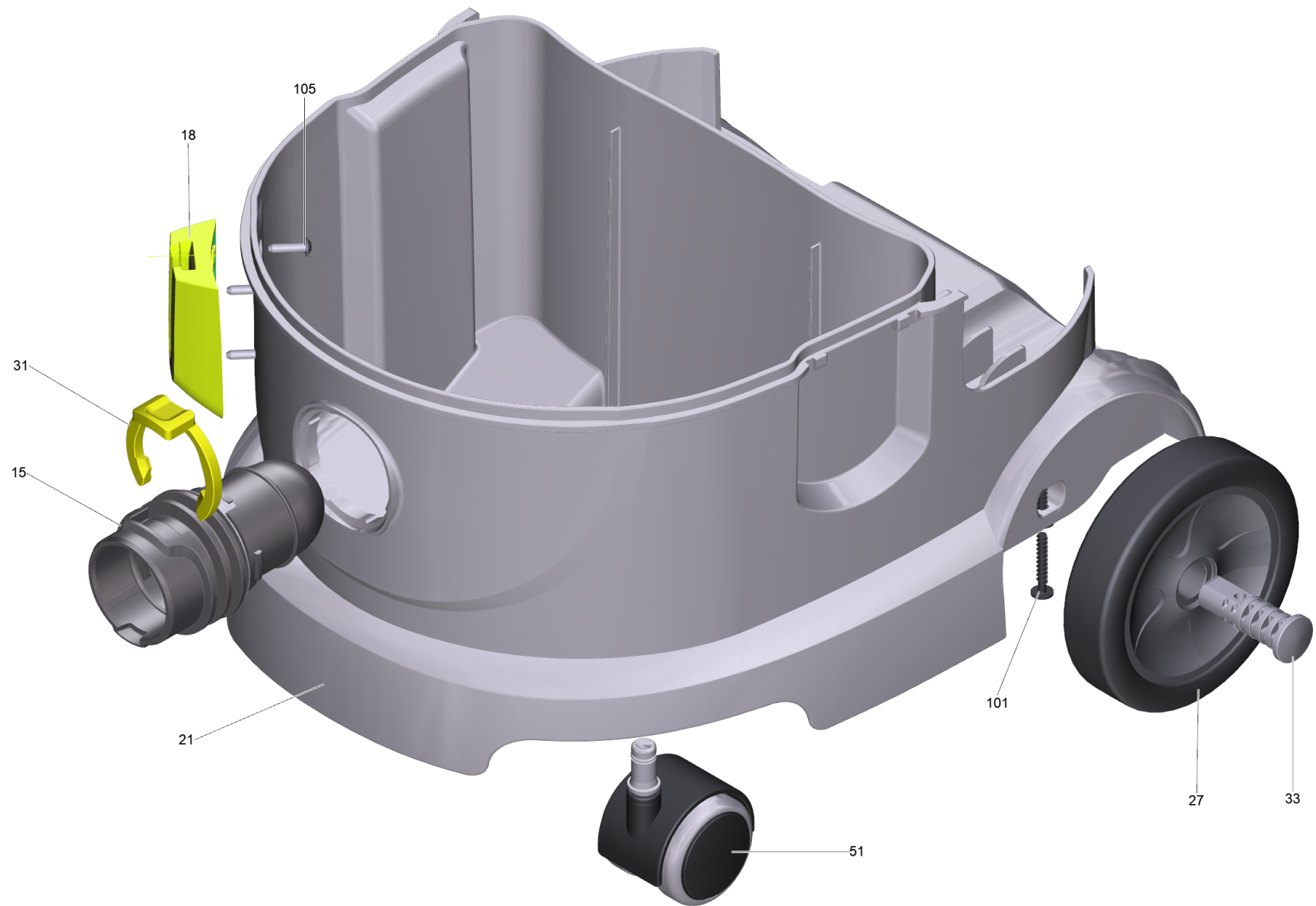



T 9/1 Bp Pack *EU (1.528-121.0)

POS	Artikelnr.	Beschreibung	Anzahl	Einheit
12		Ferritring	1	ST
15	5.034-163.0	Sauganschluss T	1	ST
16	5.034-101.0	Verschlusslasche	2	ST
18	5.032-931.0	Bodenduese Halter	1	ST
20	5.069-537.3	Haube fuer Ersatz	1	ST
21	5.071-412.0	Behaelter T 9/1 Bp Pack	1	ST
23	5.322-205.0	Griff	1	ST
24	5.324-124.0	Taster Ein/Aus RAL 1018	1	ST
25	5.363-463.0	Dichtung Turbine unten T 9/1 Bp Pack	1	ST
26	5.363-212.0	Dichtung Turbine oben T 9/1 BP	1	ST
27	5.515-355.0	Rad basaltgrau RAL 7012	2	ST
28	5.605-157.3	Gehaeuse Grundplatte fuer Ersatz T 9/1 Bp Pack	1	ST
31	5.343-022.0	Sicherungsring	1	ST
32	5.332-934.0	Feder Taster Ein/Aus	2	ST
33	5.317-379.0	Bolzen basaltgrau RAL 7012	2	ST
34	5.731-628.0	Filterkorb verpackt T9/1 Bp	1	ST
43	4.051-354.3	Kontakt Traeger Auswerfer BP/NT	1	ST
50	6.273-257.0	Dichtschnur Moosgummi D6	1	ST
51	6.435-707.0	Lenkrolle	2	ST
52	6.490-353.3	BLDC-Motor fuer Ersatz	1	ST
53	6.630-396.0	Schalter	1	ST
54	6.630-983.3	Schalter fuer Ersatz with LED	1	ST
55	4.071-644.0	Set Haube fuer Ersatz BLDC	1	ST
58	6.286-042.0	Daemmmatte Motor T 9/1 BP	1	ST
59	6.286-043.0	Daemmmatte T 9/1 BP	1	ST
62	6.414-022.0	Filter Motorschutz	1	ST
68	2.445-043.0	Battery Power+ 36/75 DW *INT	1	ST
69	4.683-275.3	Steuerung Elektronik fuer Ersatz	1	ST
70	2.445-045.0	Schnellladegeraet Battery Power+ 36/60 *EU	1	ST
79	2.889-148.0	Kruemmer verpackt antistatisch NW35 2K	1	ST
80	2.889-133.0	Schlauch verpackt NW35 2.5m	1	ST
81	2.889-129.0	Bodenduese basaltgrau verpackt NW35	1	ST
82	2.862-008.0	Teleskoprohr verpackt NW35	1	ST

T 9/1 Bp Pack *EU (1.528-121.0)

POS	Artikelnr.	Beschreibung	Anzahl	Einheit
83	6.904-335.0	Filtertüeten Vlies 10 Stck Kärcher	1	ST
85	6.900-385.0	Fugenduese DN35	1	ST
101	7.303-086.0	Schraube 5x30 -10.9-R2R (K-In6Rd)	11	ST
102	6.330-264.0	Schenkelfeder	1	ST
105	7.303-205.0	Schraube 4x16-St-10.9-R2R (In6Rd)	3	ST
106	6.645-664.0	Federring B 4	3	ST
107	7.311-001.0	6kt-Mutter M4 -6-A2E ISO 4032	3	ST
108	7.313-002.0	Federring B 5-FSt-MZN DIN 127	1	ST
109	7.311-002.0	6kt-Mutter M5 -6-A2E ISO 4032	1	ST
110	5.051-921.3	Verriegelung Batterie fuer Ersatz	1	ST
111	5.324-212.3	Entriegelungstaster Batterie fuer Ersatz T 9/1 Bp Pack	1	ST
112	5.045-147.3	Halter Batterie fuer Ersatz	1	ST
113	4.324-061.0	Set Taster	1	ST
114	5.045-082.0	Halter Schlauch rechts T 9/1 BP	1	ST
115	5.045-083.0	Halter Schlauch links T 9/1 BP	1	ST
116	6.330-160.0	Druckfeder	1	ST
120		Kabel Turbine UL T9	1	ST
123	6.650-608.0	Kabel Taster	1	ST
125	6.651-071.3	Kabel Batterie Elektronik T 9/1 Bp Pack	1	ST
126	6.651-144.3	Kabel Schalter mit LED	1	ST
127	6.651-146.3	Kabel fuer Ersatz BLDC motor communic. electronics	1	ST
900	2.889-312.0	Adapter alt verpackt NW35	1	ST

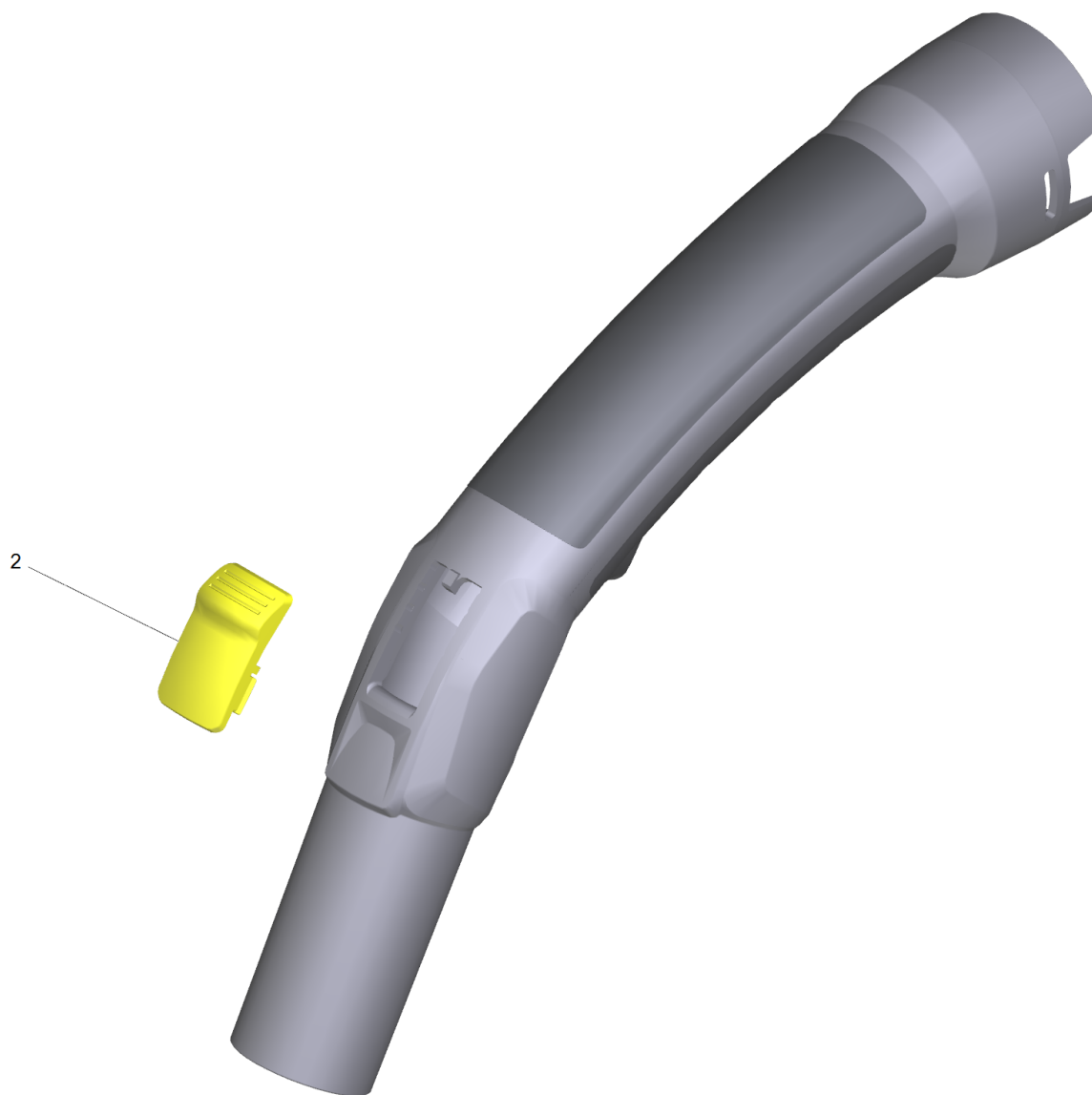

79 Kruemmer verpackt antistatisch NW35 2K (2.889-148.0)

POS	Artikelnr.	Beschreibung	Anzahl	Einheit
2	5.032-072.0	Schieber Kruemmer	1	ST

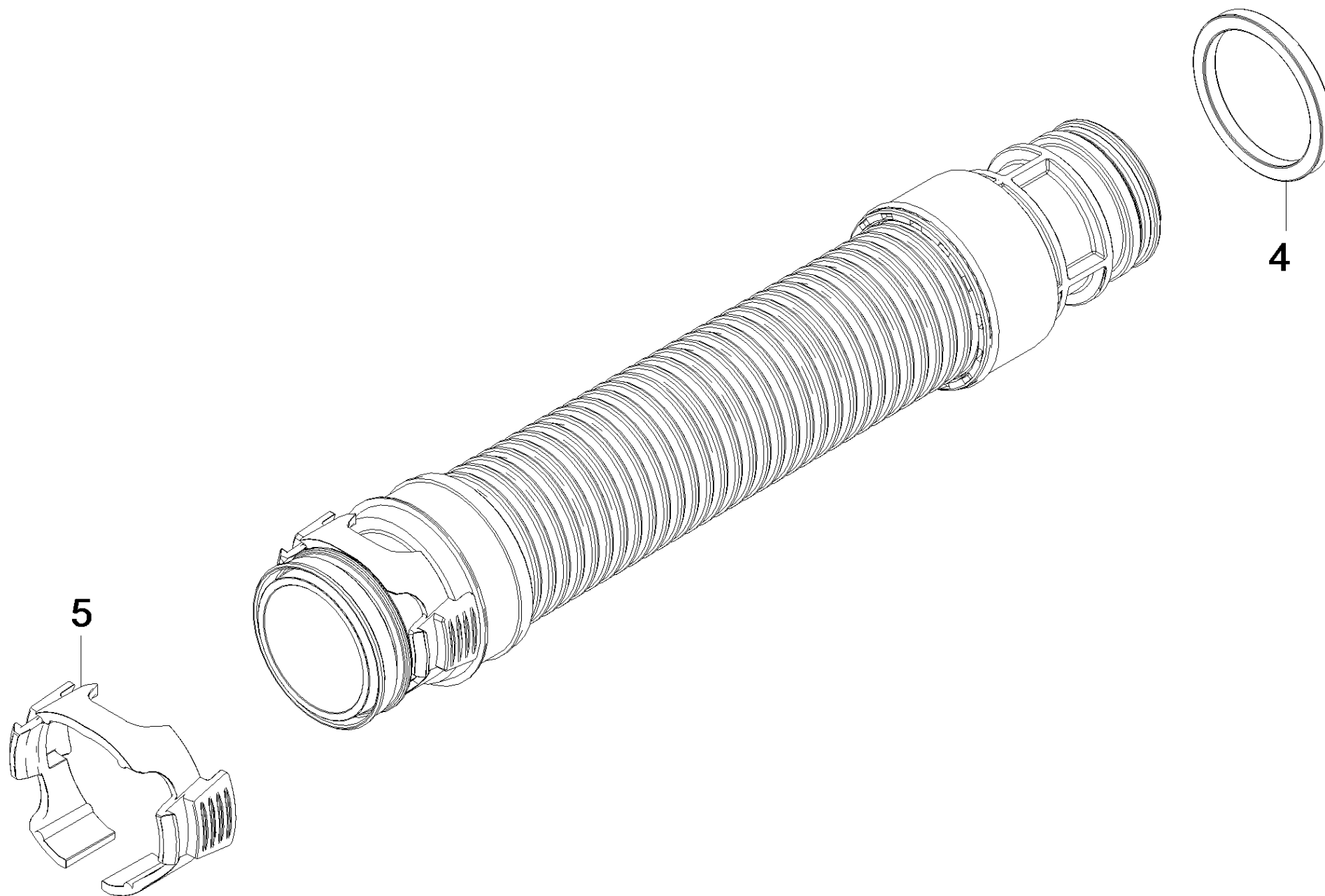

80 Schlauch verpackt NW35 2.5m (2.889-133.0)

POS	Artikelnr.	Beschreibung	Anzahl	Einheit
4	5.363-255.0	Dichtung X-Form	1	ST
5	5.031-140.0	Spannring NW35	1	ST

900 Adapter alt verpackt NW35 (2.889-312.0)

POS	Artikelnr.	Beschreibung	Anzahl	Einheit
2	5.031-703.0	Spannring C35	1	ST