

Ersatzteilliste

(6.368-464.0) Water softener 100

Inhaltsverzeichnis

Water softener 100 (6.368-464.0)	3
ETL (5.972-643.0)	4
10 Water softener 50	5
20 Water softener 100	7
30 Systemtrenner	9

Water softener 100 (6.368-464.0)

POS	Artikelnr.	Beschreibung	Anzahl	Einheit
0	5.972-643.0	ETL	1.000	ST

ETL (5.972-643.0)

POS	Beschreibung	Anzahl	Einheit
10	Water softener 50 Positionstext1: 6.368-463.0	1.000	ST
20	Water softener 100 Positionstext1: 6.368-464.0	1.000	ST
30	Systemtrenner	1.000	ST

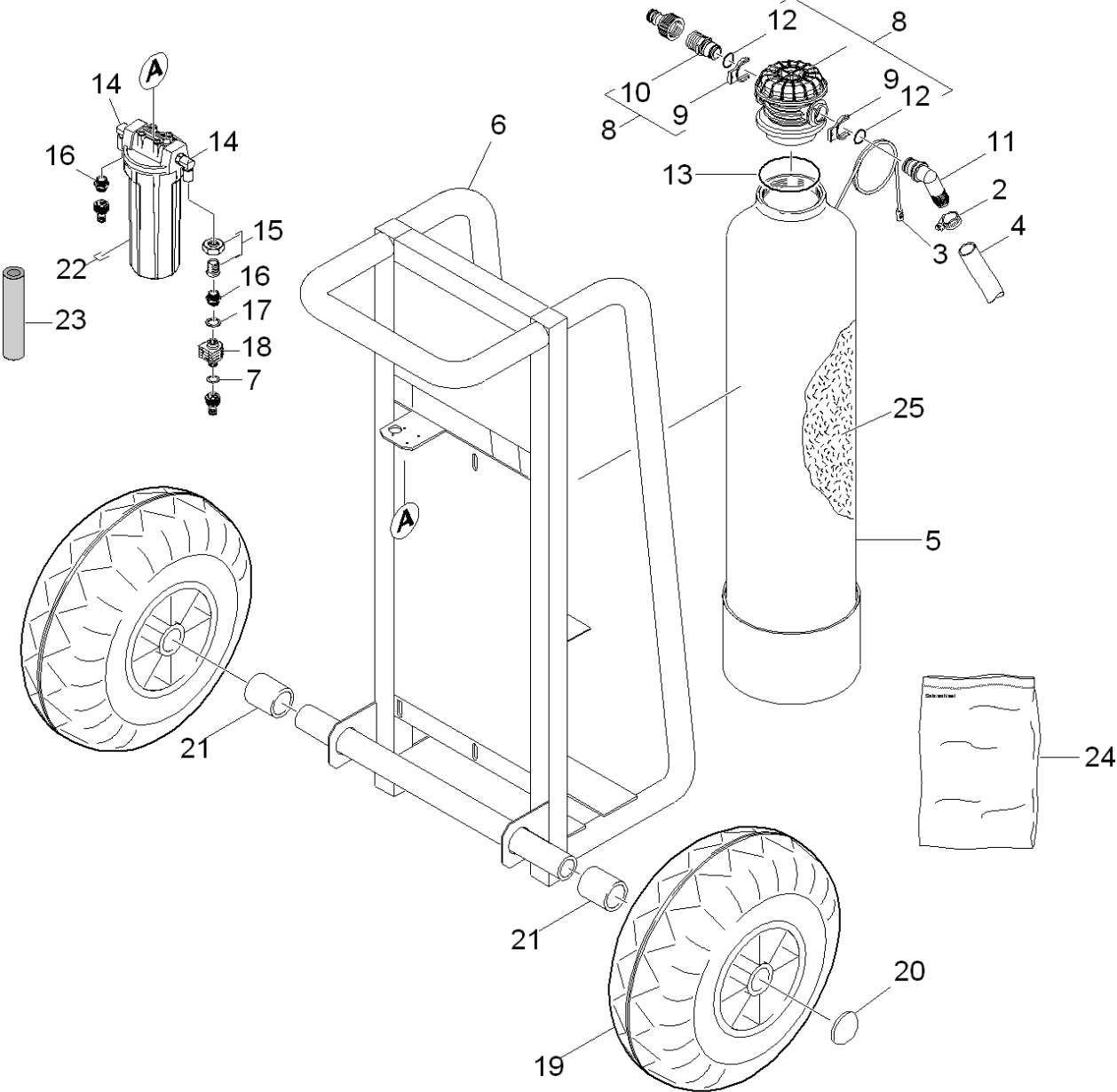

10 Water softener 50

POS	Artikelnr.	Beschreibung	Anzahl	Einheit
2	7.373-025.0	Schlauchschele A 20-32x9-W4 DIN3017	1.000	ST
3	6.761-364.0	Kugelhahn kpl.	1.000	ST
4	6.645-412.0	Schlauch 3/4" -PrimoFlex Plus	1.000	M
5	6.761-358.0	Flasche 50 l	1.000	ST
6	6.761-365.0	Rahmen	1.000	ST
7	6.645-391.0	Flachdichtung fuer G1/2	3.000	ST
8	6.761-370.0	Anschluss Armatur kpl.	1.000	ST
9	6.761-367.0	Klammer	2.000	ST
10	6.761-368.0	Stutzen gerade	1.000	ST
11	6.761-369.0	Stutzen Winkel	1.000	ST
12	6.362-079.0	O-Ring 18,0 X 2,5	2.000	ST
13	6.363-671.0	O-Ring 77,95x533 NBR	1.000	ST
14	6.387-877.0	Winkel A4-1/2"-2.1096	2.000	ST
15	6.761-371.0	Ueberwurfmutter kpl. nur fuer Ersatz	1.000	ST
16	6.387-239.0	Doppelnippel G 3/4"	1.000	ST
17	6.362-146.0	Dichtring 17x24x2	1.000	ST
18	6.761-362.0	Durchflussmesser	1.000	ST
19	6.435-008.0	Rad	2.000	ST
20	6.343-137.0	Schnellbefestiger	2.000	ST
21	5.110-378.0	Huelse	2.000	ST
22	6.642-119.0	Filter	1.000	ST
23	6.761-361.0	Filterpatrone 9 7/8"	1.000	ST
24	6.287-016.0	Enthaerter Salz ** 25 kg	1.000	ZST
25	6.761-031.0	Austauschmasse Enthaerter 25kg	1.000	ST

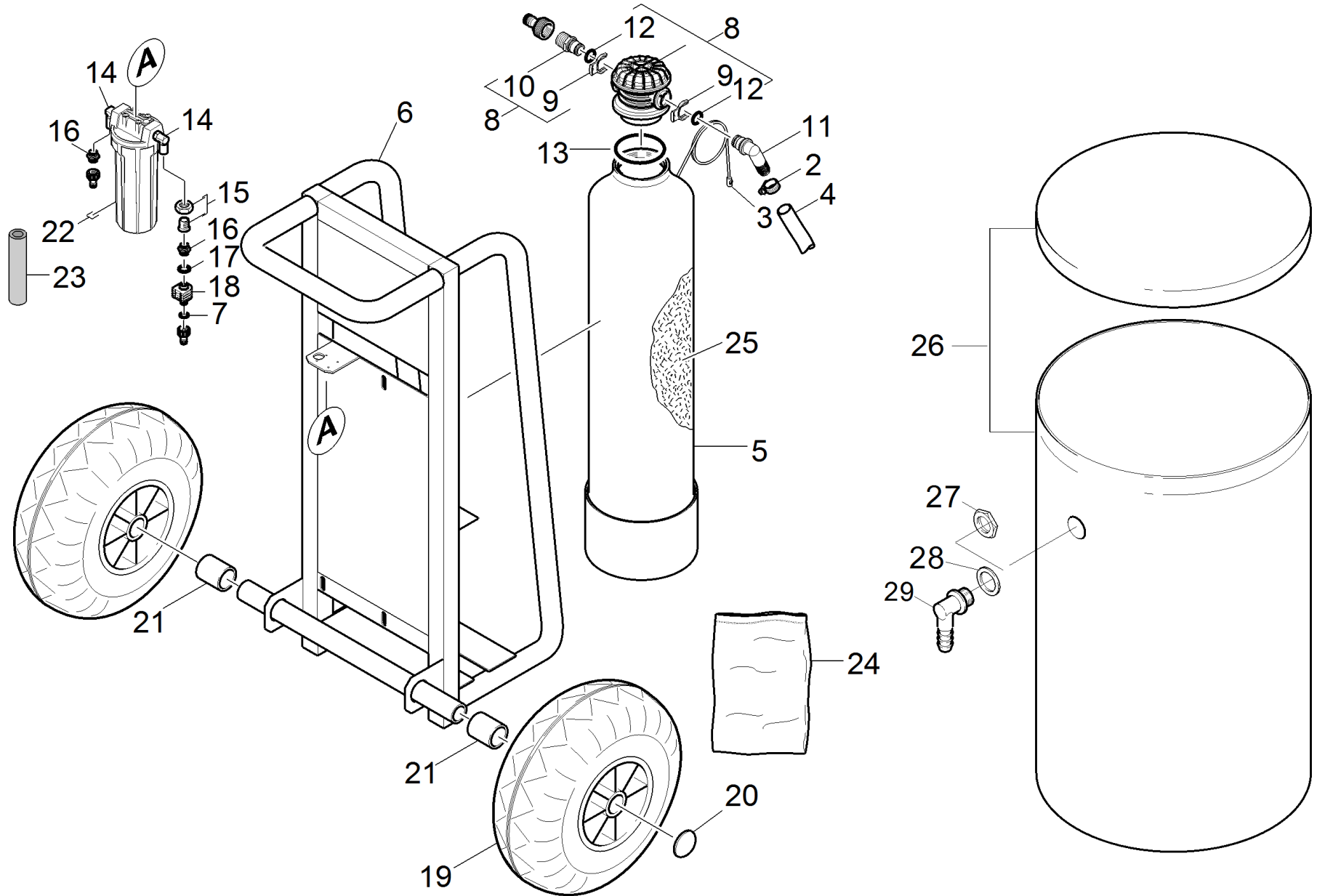

20 Water softener 100

POS	Artikelnr.	Beschreibung	Anzahl	Einheit
2	7.373-025.0	Schlauchschele A 20-32x9-W4 DIN3017	1.000	ST
3	6.761-364.0	Kugelhahn kpl.	1.000	ST
4	6.645-412.0	Schlauch 3/4" -PrimoFlex Plus	1.000	M
5	6.761-359.0	Flasche 100 l	1.000	ST
6	6.761-365.0	Rahmen	1.000	ST
7	6.645-391.0	Flachdichtung fuer G1/2	3.000	ST
8	6.761-370.0	Anschluss Armatur kpl.	1.000	ST
9	6.761-367.0	Klammer	2.000	ST
10	6.761-368.0	Stutzen gerade	1.000	ST
11	6.761-369.0	Stutzen Winkel	1.000	ST
12	6.362-079.0	O-Ring 18,0 X 2,5	2.000	ST
13	6.363-671.0	O-Ring 77,95x533 NBR	1.000	ST
14	6.387-877.0	Winkel A4-1/2"-2.1096	2.000	ST
15	6.761-371.0	Ueberwurfmutter kpl. nur fuer Ersatz	1.000	ST
16	6.387-239.0	Doppelnippel G 3/4"	1.000	ST
17	6.362-146.0	Dichtring 17x24x2	1.000	ST
18	6.761-362.0	Durchflussmesser	1.000	ST
19	6.435-008.0	Rad	2.000	ST
20	6.343-137.0	Schnellbefestiger	2.000	ST
21	5.110-378.0	Huelse	2.000	ST
22	6.642-119.0	Filter	1.000	ST
23	6.761-361.0	Filterpatrone 9 7/8"	1.000	ST
24	6.287-016.0	Enthaerter Salz ** 25 kg	1.000	ZST
25	6.761-031.0	Austauschmasse Enthaerter 25kg	1.000	ST
26	6.761-345.0	Salztank 120 L	1.000	ST
27	6.310-004.0	6kt-Mutter G 1/2"	1.000	ST
28	6.362-015.0	Dichtring 21X30X2	1.000	ST
29	6.392-290.0	Winkeltuelle 1/2"	1.000	ST

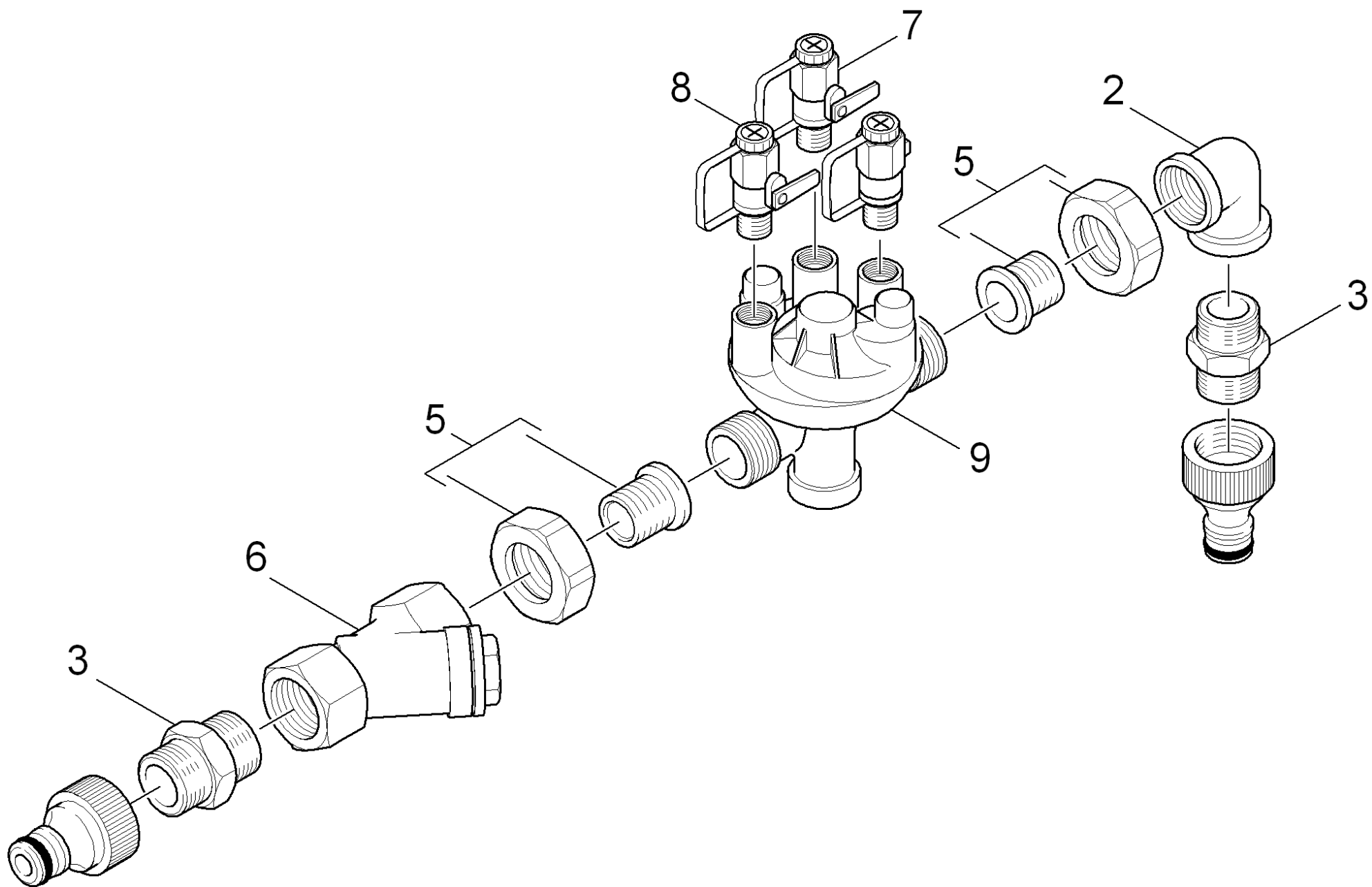

30 Systemtrenner

POS	Artikelnr.	Beschreibung	Anzahl	Einheit
1	6.761-360.0	Systemtrenner	1.000	ST
2	6.387-877.0	Winkel A4-1/2"-2.1096	1.000	ST
3	6.387-878.0	D.Nippel N8-1/2"-2.1096	1.000	ST
4	6.645-391.0	Flachdichtung fuer G1/2	2.000	ST
5	6.761-371.0	Ueberwurfmutter kpl. nur fuer Ersatz	2.000	ST
6	6.761-372.0	Filtergehaeuse kpl. nur fuer Ersatz	1.000	ST
7	6.761-373.0	Absperrhahn kpl. nur fuer Ersatz	3.000	ST
8	6.761-374.0	Verschlusskappe nur fuer Ersatz	3.000	ST
9	6.761-375.0	Gehaeuse Systemtrenner nur fuer Ersatz	1.000	ST